



# SELF SERVICE B.SMART

## CARATTERISTICHE

- B.SMART CLOUD SOFTWARE
- NESSUNA INSTALLAZIONE SOFTWARE
- ADATTO A FLOTTE DI TUTTE LE DIMENSIONI
- FEEDBACK IN TEMPO REALE DA QUALSIASI LOCATION
- ALL-IN-ONE EQUIPMENT
- FILTRO INTEGRATO
- KIT UPGRADE 1.0/2018 INCLUSO
- DESIGN COMPATTO

La tecnologia di qualità PIUSI integrata con l'innovativo sistema di gestione carburanti B.SMART: questo è il cuore della nuova SELF SERVICE B.SMART. Un dispenser completo all-in-one sviluppato espressamente per rispondere non solo a tutte le esigenze di erogazione gasolio ma anche, nel contempo, di controllo, gestione e monitoraggio dei consumi di una flotta aziendale; proprio come un software di gestione. SELF SERVICE B.SMART è dotata di una struttura robusta che garantisce le massime performance in qualsiasi condizione d'utilizzo, una pompa a palette con bypass incorporato e portata fino a 90 l/min e un contaltri ad ingranaggi ovali per la massima precisione di misurazione. La pistola automatica con swivel, ergonomica e facile da impugnare e il filtro per l'assorbimento di acqua completano le componenti.

### PERFORMANCE

<b>FINO A</b> <b>90 L/MIN</b>	<b>AC</b> <b>VOLTAGGIO</b>
PORTATA	POTENZA
<b>± 0,5%</b>	<b>BLUETOOTH</b>
PRECISIONE	CONNESSIONE

**NEW**

Aggiorna il suo sistema MC a B.Smart con il KIT HARDWARE 1.0/2018 UPGRADE



SELF SERVICE B.SMART



### PACKAGING

CODICE	PESO		PACKAGING			N. BOX / EUROPALLET	
	KG	LBS	MM	INCH	PCS/BOX	✕	
FO0748010	57	125	1480X490X400	58,3X19,3X15,7	1		
FO0748040	57	125	1480X490X400	58,3X19,3X15,7	1		
FO0748060	57	125	1480X490X400	58,3X19,3X15,7	1		
FO0748000	61	133	1480X490X400	58,3X19,3X15,7	1		
FO0748030	61	133	1480X490X400	58,3X19,3X15,7	1		
FO0748070	61	133	1480X490X400	58,3X19,3X15,7	1		



FILTRAZIONE



MONITORAGGIO FLUIDI



ARROTOLATORI



ACCESSORI



MERCHANDISE



ARIA



ANTIGELO



AdBlue®



BIODIESEL



DIESEL



ALIMENTI



BENZINA



GRASSO



KEROSENE



OLIO



ACQUA



LAVAVETRI

## GRAFICO

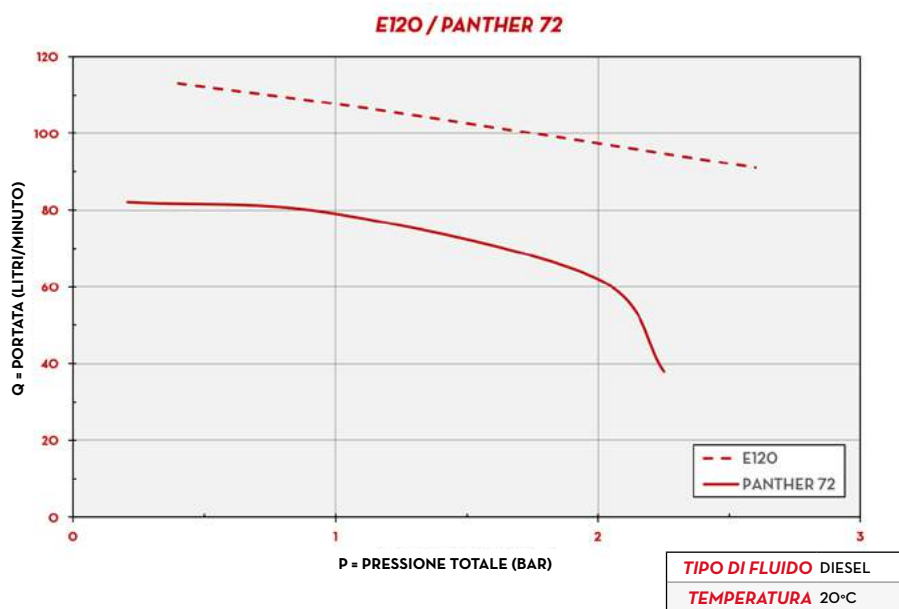

## DIMENSIONI

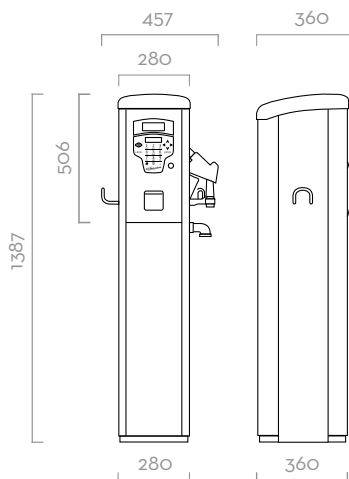

Dimensioni espresse in millimetri

## DENTRO LA SCATOLA

- DISPENSER SELF SERVICE B.SMART
- PISTOLA AUTOMATICA
- TUBO DI MANDATA
- ADD-ON DRIVER ACCESS
- MANUALE ISTRUZIONI

## DETTAGLI



## MATERIALI

- **POMPE:**  
PANTHER 72 / E120 PAG. 102/106
- **CONTALITRI:**  
K600/3 PAG. 134
- **PISTOLA:**  
PISTOLA AUTOM. PAG. 158
- **FILTRO:**  
WATER CAPTOR PAG. 170

## DATI TECNICI

CODICE	DESCRIZIONE	TIPO DI FLUIDO	PORTATA		VOLTAGGIO			PUMP	METER	NOZZLE	FILTER	INGRESSO	HOSE		
			L/MIN	GPM	AC V/HZ	DC VOLT	POTENZA WATT						AMP. MAX.	LUNGH.	Ø
FO0748010	SELF SERVICE 70 230V B.SMART 10 DRIVERS	D	70	18	230 V	50 HZ	550 W	3,3 A	PANTHER 72	K600/3	A120	30 µM	11/2"	4M	25MM
FO0748040	SELF SERVICE 70 230V B.SMART 20 DRIVERS	D	70	18	230 V	50 HZ	550 W	3,3 A	PANTHER 72	K600/3	A120	30 µM	11/2"	4M	25MM
FO0748060	SELF SERVICE 70 230V B.SMART 50 DRIVERS	D	70	18	230 V	50 HZ	550 W	3,3 A	PANTHER 72	K600/3	A120	30 µM	11/2"	4M	25MM
FO0748000	SELF SERVICE 100 230V B.SMART 10 DRIVERS	D	90	24	230 V	50 HZ	1150 W	5,7 A	E120	K600/3	A120	30 µM	11/2"	4M	25MM
FO0748030	SELF SERVICE 100 230V B.SMART 20 DRIVERS	D	90	24	230 V	50 HZ	1150 W	5,7 A	E120	K600/3	A120	30 µM	11/2"	4M	25MM
FO0748070	SELF SERVICE 100 230V B.SMART 50 DRIVERS	D	90	24	230 V	50 HZ	1150 W	5,7 A	E120	K600/3	A120	30 µM	11/2"	4M	25MM

# SELF SERVICE B.SMART