



RIFORMIMENTO  
AUTO



FUEL MANAGEMENT  
SYSTEMS



KITS



POMPE



CONTALTRI



PISTOLE  
CONTALTRI

# PIUSIBOX CAR SUCTION

## CARATTERISTICHE

- IDEALE PER SVUOTARE SERBATOI DI VEICOLI
- EVITA UN RIEMPIMENTO ECCESSIVO DEL SERBATOIO
- POMPA A MEMBRANA SUZZARABLU
- FACILE DA MANEGGIARE

PIUSI BOX CAR SUCTION è la soluzione perfetta per chi deve svuotare un serbatoio di un veicolo che contiene AdBlue® prima di sottoporlo a manutenzione. Viene fornito con una scatola portatile che contiene tutte le attrezzature necessarie.

## PERFORMANCE

FINO A

**34 L/MIN**

PORTATA

**AC**

VOLTAGGIO

POTENZA

MAX

**2M**

LUNGHEZZA TUBO

DISPONIBILE CON

**ON/OFF**

PULSANTE

INTERRUTTORE



PIUSIBOX CAR SUCTION



## PACKAGING

CODICE	PESO		PACKAGING		
	KG	LBS	MM	INCH	PEZZI/BOX
FOO201R20	11,5	25,3	650X400X450	25,6X15,7X17,7	1



PISTOLE



FILTRAZIONE



MONITORAGGIO FLUIDI



ARROTOLATORI



ACCESSORI



MERCHANDISE



ARIA



ANTIGELO



AdBlue®



BIODIESEL



DIESEL



ALIMENTI



BENZINA



GRASSO



KEROSENE



OLIO



ACQUA



LAVAVETRI

## FUNZIONAMENTO

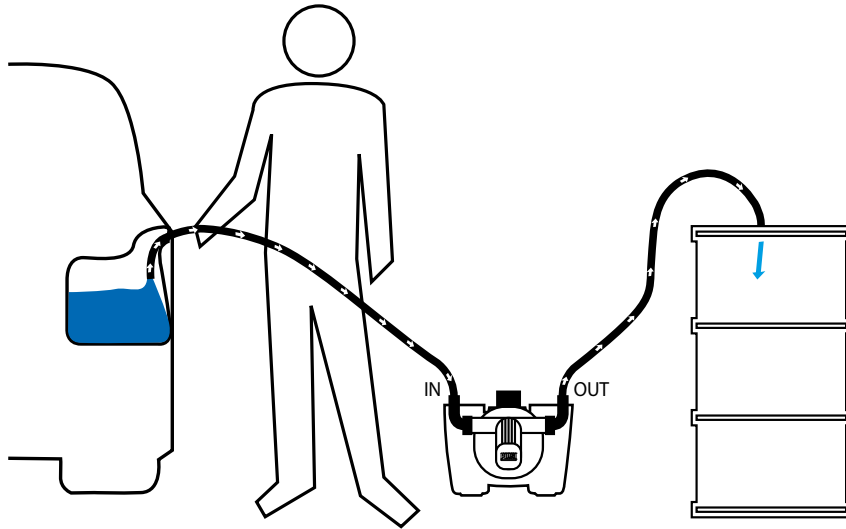

## DENTRO LA SCATOLA

- POMPA SUZZARBLUE
- TUBO DI ASPIRAZIONE/MANDATA
- MANUALE ISTRUZIONI

## DETTAGLI



ON/OFF INTERRUPTORE



SUZZARBLUE PUMP AC



MANIGLIA

## DIMENSIONI

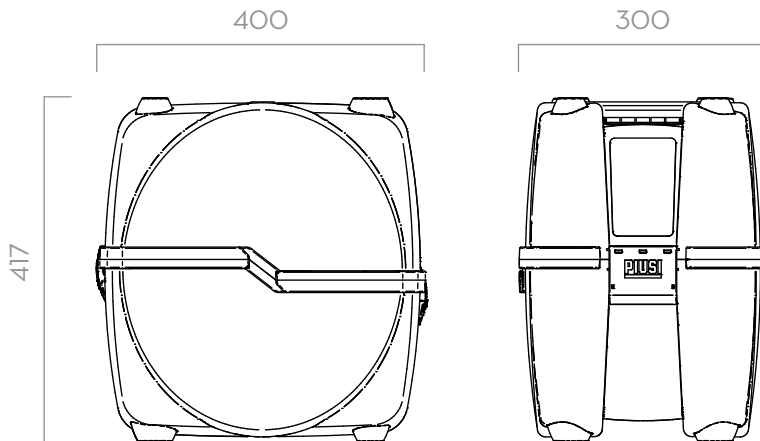

Dimensioni espresse in millimetri

## MATERIALI

- POMPA:
- CORPO: POLIPROPILENE
- MEMBRANA: POLIPROPILENE

## DATI TECNICI

CODICE	DESCRIZIONE	TIPI DI FLUIDO	PORTATA		VOLTAGGIO			RPM	CICLO DI LAVORO		CAVI	TUBO DI ASPIRAZIONE 12 MM Ø	TUBO DI MANDATA 12 MM Ø
			L/MIN	GPM	AC V/ HZ	DC VOLT	POTENZA WATT		AMP. MAX.	RPM		MIN	LUNGHEZZA (M)
FOO201R20	PIUSIBOX CAR SUCTION ADBLUE		34	9	230/50	400	1,95	1450	20	SI	2	2	

# PIUSIBOX CAR SUCTION