



FUEL MANAGEMENT
SYSTEMS



DISPENSERS



KITS



POMPE



CONTALITRI



PISTOLE

PITSTOP

CARATTERISTICHE

- PRONTO PER IL MONTAGGIO
- VERSATILITÀ
- STRUTTURA ROBUSTA

PIUSI PITSTOP è un dispenser con due pompe DC, arrotolatore automatico, filtro acqua e pistola automatica con tubo da 14 metri integrati in una robusta struttura portante. Facile da montare, versatile e compatto, questo dispenser è la soluzione completa per realizzare un'unità di rifornimento mobile perfetta.

PERFORMANCE

FINO A

45 L/MIN

PORTATA

12/24V

VOLTAGGIO

POTENZA

14MT

LUNGHEZZA TUBO

ARROTOLATORE

200β/30μ

CAPACITÀ FILTRANTE



PITSTOP



PACKAGING

CODICE	PESO		PACKAGING		
	KG	LBS	MM	INCH	PCS/BOX
FO0212000	45	99	595X465X670	23,4X13,5X24,4	1
FO0213000	45	99	595X465X670	23,4X13,5X24,4	1



FILTRAZIONE



MONITORAGGIO FLUIDI



ARROTOLATORI



ACCESSORI



MERCHANDISE



ARIA



ANTIGELO



AdBlue®



BIODIESEL



DIESEL



ALIMENTI



BENZINA



GRASSO



KEROSENE



OLIO



ACQUA



LAVAVETRI

GRAFICO

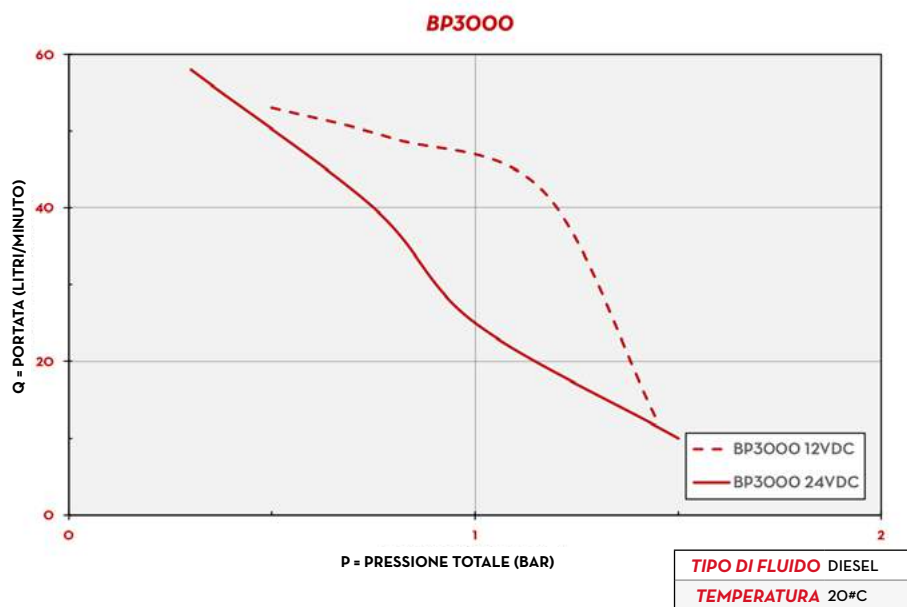

DIMENSIONI

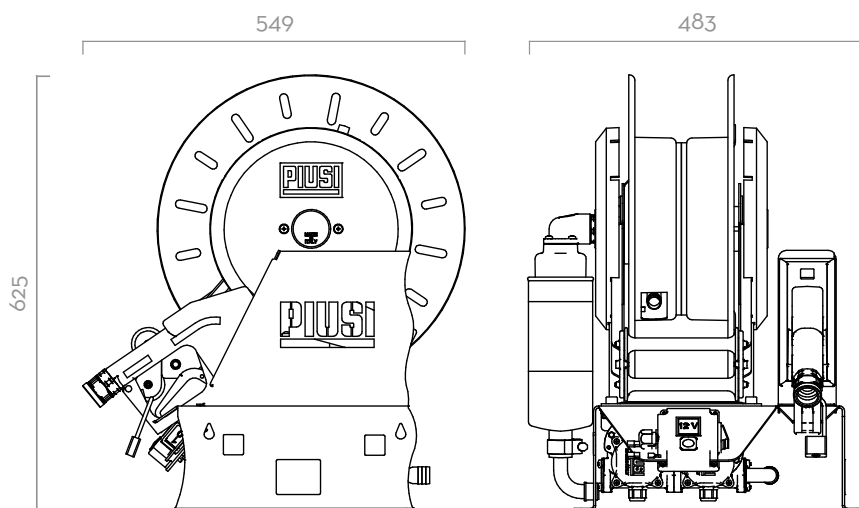

Dimensioni espresse in millimetri

DENTRO LA SCATOLA

- PITSTOP
- PISTOLA AUTOMATICA
- FILTRO
- MANUALE ISTRUZIONI

DETTAGLI



SELETTORE ON/OFF



LUCCHETTO



POMPE DC INTEGRATE



BRACCIO REGOLABILE

COMPONENTI

- **POMPA:**
BP3000 PAG. 112
- **FILTRO:**
WATER CAPTOR PAG. 170
- **PISTOLA:**
A60 PAG. 158

DATI TECNICI

CODICE	DESCRIZIONE	TIPO DI FLUIDO	PORTATA		VOLTAGGIO			PUMP		DUTY CYCLE	NOZZLE	HOSE	INGRES-	
			L/MIN	GPM	AC V/HZ	POTEN-	AMP.	TIPO	N°	MINUTI	TIPO	LUNGH.	Ø	SO
FO0212000	PIUSI PITSTOP DC 12V	D	45	11,9	12	400	33	BP 3000	2	30	A60	14M	3/4"	1"
FO0213000	PIUSI PITSTOP DC 24V	D	45	11,9	24	620	26	BP 3000	2	30	A60	14M	3/4"	1"