



FUEL MANAGEMENT  
SYSTEMS



DISPENSERS



KITS



POMPE



CONTALITRI



PISTOLE

# PANTHER AC

## CARATTERISTICHE

- DESIGN COMPATTO E ROBUSTO
- PRONTO ALL'USO
- FACILE DA MONTARE
- FILTRO INTEGRATO

PIUSI PANTHER AC è una elettropompa rotativa a palette autoadescanti disponibile in tre versioni (56 - 72 - 90) particolarmente adatta per dispenser, sistemi fissi di travaso carburante e altre applicazioni industriali. È dotato di una valvola di by-pass e di un filtro incorporato per bloccare le impurità.

### PERFORMANCE

FINO A

**90 L/MIN**

PORTATA

**AC**

CONTINUO DUTY\*

POTENZA



PANTHER 56 (flange non include)



PANTHER 72 - PANTHER 90 (flange include)



### PACKAGING

CODICE	PESO		PACKAGING			N. BOX / EUROPALET	
	KG	LBS	MM	INCH	PCS/BOX	✈	🚚
<b>PANTHER 56</b>							
FO0730000	7,4	16,3	345X175X255	-	1	60	84
000731000	7,4	16,3	345X175X255	-	1	60	84
000733000	7,4	16,3	345X175X255	-	1	60	84
<b>PANTHER 72</b>							
000732000	7,9	17,4	345X175X255	-	1	60	84
000735000	7,9	17,4	345X175X255	-	1	60	84
<b>PANTHER 90</b>							
FO0733020	9,007	19,9	345X175X255	-	1	60	84



FILTRAZIONE



MONITORAGGIO FLUIDI



ARROTOLATORI



ACCESSORI



MERCHANDISE



ARIA



ANTIGELO



AdBlue®



BIODIESEL



DIESEL



ALIMENTI



BENZINA



GRASSO



KEROSENE



OLIO



ACQUA



LAVAVETRI

## GRAFICO

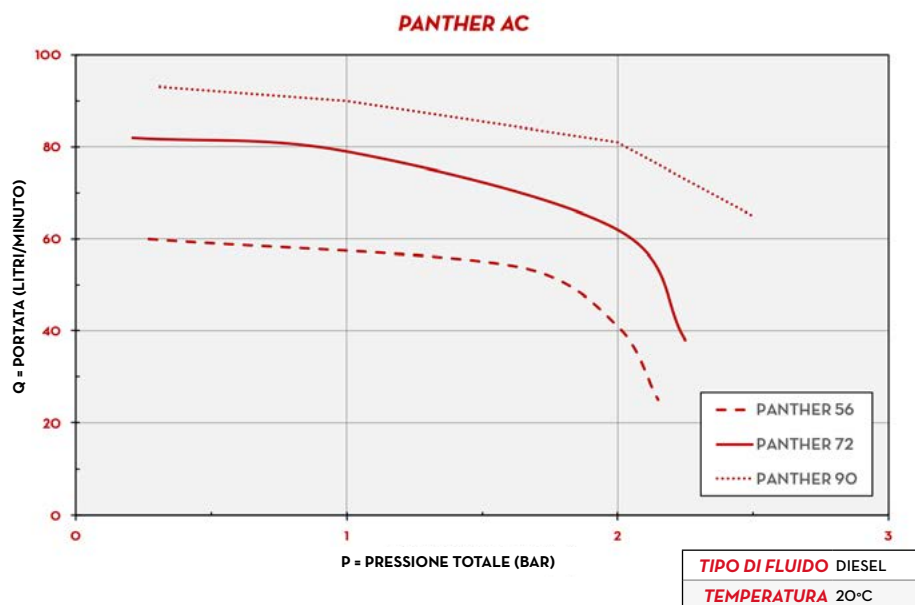

## DENTRO LA SCATOLA

- POMPA PANTHER AC
- MANUALE ISTRUZIONI

## DETTAGLI



## DIMENSIONI

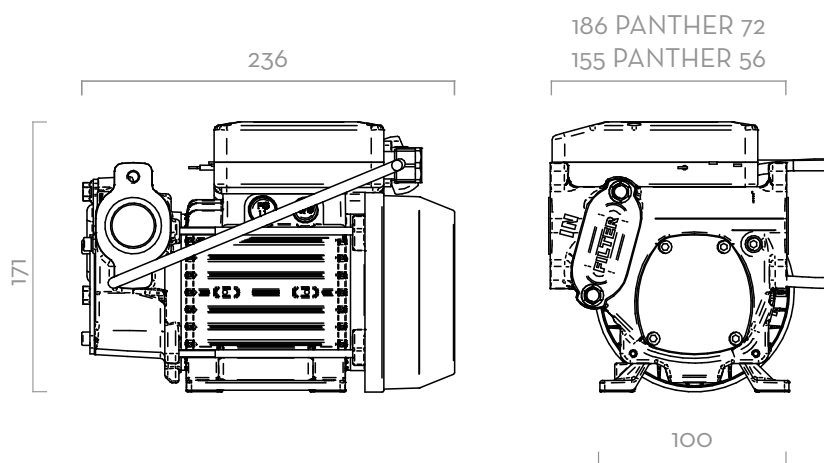

Dimensioni espresse in millimetri

## MATERIALI

- CORPO: GHISA
- ROTORE: ACCIAIO SINTERIZZATO
- PALETTE: TECNOPOLIMERO
- ALBERO: ACCIAIO



POMPA

- MASSIMO 6M (20FT),
- TUBO DI ASPIRAZIONE Ø 1" MIN,
- MASSIMA ALTEZZA D'ASPIRAZIONE:
  - 2M (7FT) SENZA VALVOLA DI NON RITORNO
  - 4M (14FT) CON VALVOLA DI NON RITORNO



FUSTO

## DATI TECNICI

CODICE	DESCRIZIONE	TIPO DI FLUIDO	PORTATA		VOLTAGGIO				RPM	INGRESSO USCITA BSP	COCONNESSIONI FLANGIATE	VAL-VOA DI BAYPASS	INGRES-SO FILTRO	DUTY CYCLE MINUTE	
			L/MIN	GPM	SINGLEPHASE MOTOR V./HZ	THREEPHASE MOTOR V./HZ	POTEN-ZA WATT	AMP. MAX.							
<b>PANTHER 56</b>															
FO0730000	PANTHER 56 230/50	D	56	15	230/50	-	350	3	2900	1"	-	SI	SI		
000731000	PANTHER 56 230/60	D	70	18	230/60	-	500	3,9	3400	1"	-	SI	SI		
000733000	PANTHER 56 400/50	D	56	15	-	400/50	500	1,3	2900	1"	-	SI	SI		
<b>PANTHER 72</b>															
000732000	PANTHER 72 230/50	D	72	19	230/50	-	500	4,2	2900	1"	SI	SI	SI		
000735000	PANTHER 72 400/50	D	72	19	-	400/50	500	1,6	2900	1"	SI	SI	SI		
<b>PANTHER 90</b>															
FO073302A	PANTHER 90 230/50	D	90	23,8	230/50	-	700	4,9	2900	1"	SI	SI	SI	30	

SU RICHIESTA È DISPONIBILE CON DIVERSI VOLTAGGIO E FREQUENZA (\*) ECCETTO PANTHER 90

# PANTHER AC