



FUEL MANAGEMENT SYSTEMS



DISPENSERS



KITS



POMPE



CONTALITRI



PISTOLE

K600/3

CARATTERISTICHE

- FLANGE REGOLABILI
- ADATTO PER APPLICAZIONI INDUSTRIALI
- IDEALE PER INSTALLAZIONI MOBILI
- BASSO CONSUMO ENERGETICO

K600/3 di PIUSI è un contaltri a ingranaggi ovali adatto per monitorare l'erogazione di diesel, oli e antigelo. Il contaltri è dotato di filtro integrato ed è disponibile anche in versione pulser.

PERFORMANCE

FINO A
10-100 L/MIN

PORTATA

MAX
30 BAR

PRESSIONE D'ESERCIZIO

± 0,5%

PRECISIONE

0,2%

RIPETIBILITÀ



K600/3 CONTALITRI

K600/3 PULSER

PACKAGING

CODICE	PESO		PACKAGING		
	KG	LBS	MM	INCH	PCS/BOX
METER					
FOO496A00	1,6	3,5	200X120X140	7,9X4,7X5,5	1
PULSER					
FOO472A00	2,6	5,7	200X120X140	7,9X4,7X5,5	1



FILTRAZIONE



MONITORAGGIO FLUIDI



ARROTOLATORI



ACCESSORI



MERCHANDISE



ARIA



ANTIGELO



AdBlue®



BIODIESEL



DIESEL



ALIMENTI



BENZINA



GRASSO



KEROSENE



OLIO



ACQUA



LAVAVETRI

GRAFICO

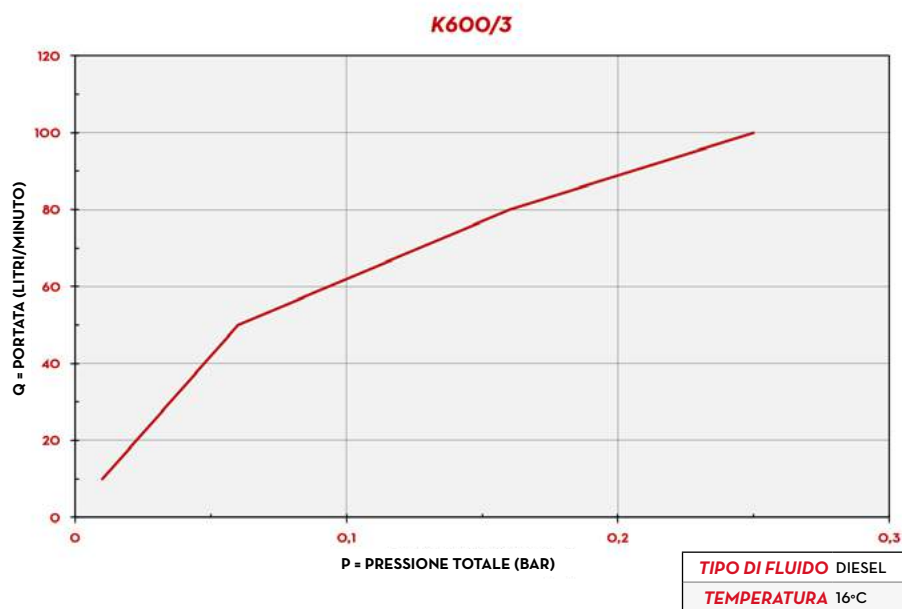

DENTRO LA SCATOLA

- CONTALITRI K600/3
- FLANGE
- MANUALE ISTRUZIONI

DETTAGLI



DISPLAY A 5 CIFRE



INGRANAGGI OVALI

DIMENSIONI

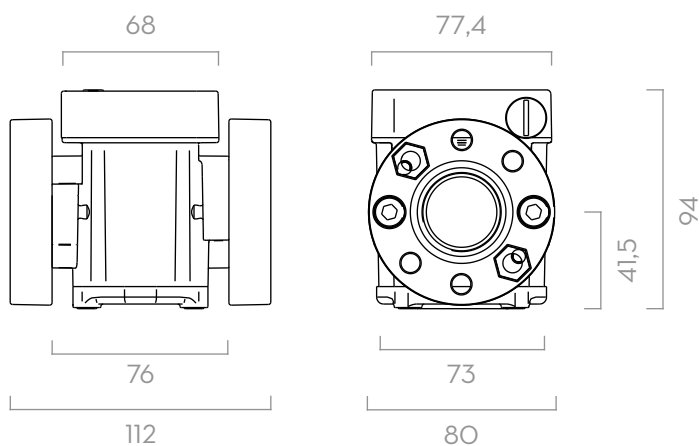

Dimensioni espresse in millimetri

MATERIALI

- CORPO: ALLUMINIO
- INGRANAGGI: TECNOPOLIMERO

DATI TECNICI

CODICE	DESCRIZIONE	TIPO DI FLUIDO	PORTATA		PRESSIONE		BATTERIA N°2 X 1,5V (INCLUSA)	FLANGE	INGRESSO / OUTLET	INGRESSO FILTER
			L/MIN	GPM	BAR	PSI				
METER										
FOO496A00	K600/3 DIESEL	A D O	10 - 100	2,64 - 26,4	30	426	SI	SI	1" BSP	SI
PULSER										
FOO472A00	K600/3 1" DIESEL	A D O	10 - 100	2,64 - 26,4	30	426	NO	SI	1" BSP	SI

A RICHIESTA DISPONIBILE IN VERSIONE NPTF E DISPLAY IN GALLONI O STAMPA

K600/3