



KITS



POMPE



CONTALTRI

PISTOLE
CONTALTRI

PISTOLE

ATTREZZATURE
OLIO ESAUSTO

K500

CARATTERISTICHE

- FUNZIONE DI PRESELEZIONE
- ELEVATA PRECISIONE
- BATTERIA STANDARD AA
- IMPUGNATURA ERGONOMICA
- BECCUCCIO ROTANTE
- PROTEZIONE ANTI-URTO
- PROTEZIONE IP55
- UMA REGOLABILE

K500 di PIUSI è la pistola per olio con preselezione più diffusa. Dispone di manico ergonomico, contaltri a ingranaggi ovali e di una funzione di preselezione che consente di scegliere sempre la quantità giusta prima dell'erogazione.

PERFORMANCE

FINO A

30 L/MIN

PORTATA

70 BAR

PRESSIONE D'ESERCIZIO

± 0,5%

PRECISIONE

FINO A

2000 CST

VISCOSITÀ



K500



A

SPOUT RUOTABILE
R12519000
PAG. 96



B

SPOUT FLESSIBILE
FO0676070
PAG. 96



C

SPOUT RIGIDO
FO0676080
PAG. 96



PACKAGING

CODICE	PESO		PACKAGING			N. BOX/ EUROPALLE	
	KG	LBS	MM	PEZZI/PALLET	PEZZI/BOX		
FO068700D	1,8	4	280X160X140		1	128	160
FO068720A	1,8	4	280X160X140		1	128	160
FO068721A	1,8	4	280X160X140		1	128	160



FILTRAZIONE



MONITORAGGIO FLUIDI



MONITORAGGIO SERBATOI



ARROTOLATORI



ACCESSORI



MERCHANDISE



ARIA



ANTIGELO



AdBlue®



BIODIESEL



DIESEL



ALIMENTI



BENZINA



GRASSO



KEROSENE



OLIO



ACQUA



LAVAVETRI

GRAFICO

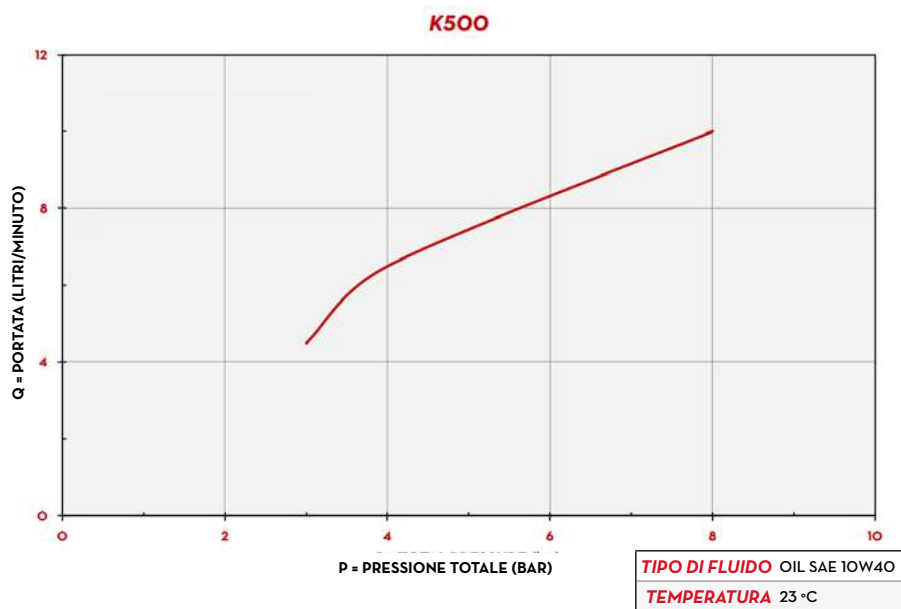

DIMENSIONI

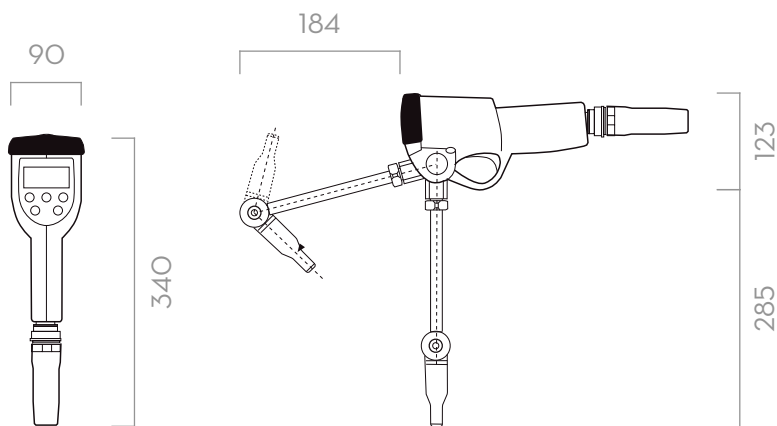

Dimensioni espresse in millimetri

DENTRO LA SCATOLA

- PISTOLA K500
- MANUALE ISTRUZIONI

DETTAGLI



QUANTITÀ FACILMENTE PRESELEZIONABILE



ELEVATA PROTEZIONE



CONTALITRI CON INGRANAGGI OVALI



VANO BATTERIE

MATERIALI

- CORPO PISTOLA: ALLUMINIO
- VALVOLA: NBR, ACCIAIO NICHELATO, OTTONE
- CORPO CONTALITRI: ALLUMINIO
- INGRANAGGI: TECNOPOLIMERO

DATI TECNICI

CODICE	DESCRIZIONE	TIPO DI FLUIDO	SPOUT TIPO	SALVAGOCCIA AUTOMATICO	PORTATA		PRESSIONE D'ESERCIZIO		BATTERIE TAGLIA 1,5 V AA NO.	INLET
					L/MIN	GPM	BAR	PSI		
FO068700D	K500 PRESET NOZZLE .75" BSP W/ROT SPOUT	O	A	SI	1 ÷ 30	0,26 ÷ 7,8	70	994	4	1/2" BSP
FO068720A	K500 PRESET NOZZLE .75" BSP W/RIGID SPOU	O	C	SI	1 ÷ 30	0,26 ÷ 7,8	70	994	4	1/2" BSP
FO068721A	K500 PRESET NOZZLE .75" BSP W/FLEX SPOUT	O	B	SI	1 ÷ 30	0,26 ÷ 7,8	70	994	4	1/2" BSP

K500