



KITS



POMPE



CONTALITRI

PISTOLE
CONTALITRI

PISTOLE

ATTREZZATURE
OLIO ESAUSTO

FILTROLL

CARATTERISTICHE

- FILTRAZIONE A DUE FASI
- INDICATORE INTASAMENTO
- TRASPORTABILE
- PRATICO
- TUBI SPIRALATI

FILTROLL di PIUSI è una soluzione innovativa che consente all'utente di effettuare una filtrazione circolare di qualsiasi tipo di serbatoio. La struttura carrellata consente all'operatore di spostare facilmente questo gruppo in qualsiasi condizione.

PERFORMANCE

FINO A

25L/MIN

PORTATA

AC**VOLTAGGIO**

POTENZA

VERSIONE DC

30MIN

SOLO PER DIESEL

CICLO DI FUNZIONAMENTO

**FILTROLL OIL/DIESEL**

PACKAGING

CODICE	PESO		PACKAGING			
	KG	LBS	MM	INCH	PEZZI/PALLET	PEZZI/BOX
FO0506010	42	92,6	790X590X590	31,1X23,2X23,2		1



FILTRAZIONE



MONITORAGGIO FLUIDI



MONITORAGGIO SERBATOI



ARROTOLATORI



ACCESSORI



MERCHANDISE



ARIA



ANTIGELO



AdBlue®



BIODIESEL



DIESEL



ALIMENTI



BENZINA



GRASSO



KEROSENE



OLIO



ACQUA



LAVAVETRI

GRAFICO

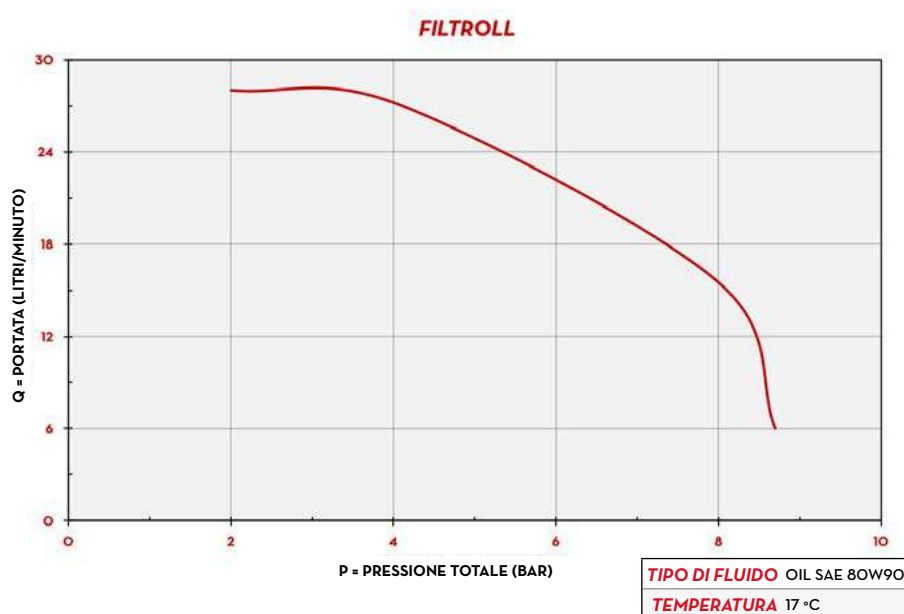

DIMENSIONI

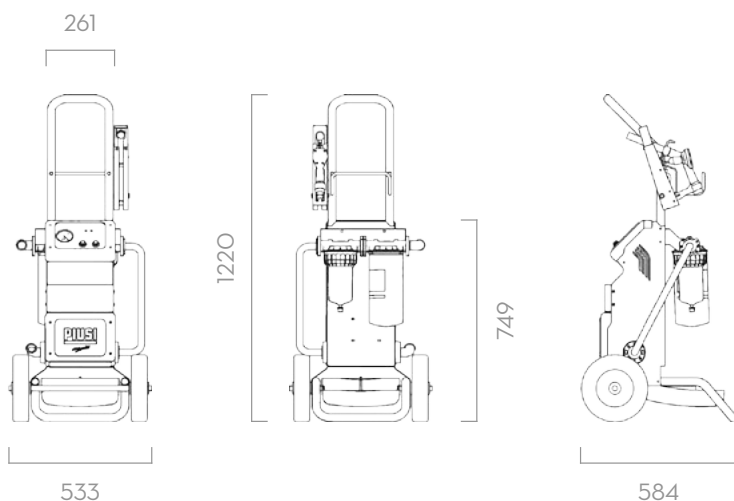

Dimensioni espresse in millimetri

DATI TECNICI

CODICE	DESCRIZIONE	TIPO DI FLUIDO	PORTATA		VOLTAGGIO			POMPA	LUNGHEZZA TUBO	
			L/MIN	GPM	AC V/HZ DC VOLT	POTENZA WATT	AMP. MAX.		MANDATA M/FT	ASPIRAZIONE M/FT
FOO506010	FILTROLL OIL/DIESEL	D O	25	7	230/50	750	4,6	VISCOMAT 70	3 / 9,8	3 / 9,8

CARTUCCIA PER FILTRO

CODICE	DESCRIZIONE	MICRO	EFFICIENZA
		µ m	
FOO61102A	WATER CAPTOR CART. 150 L/MIN	30	200
FOO61103O	CLEAR CAPTOR CARTRIDGE	5	2

TESTATA DEL FILTRO

F1693400A	FILTER HEAD 70/100LT W/MANOM	-	-
F15744000	CLEAR CAPTOR FILTER HEAD	-	-

DENTRO LA SCATOLA

- FILTROLL
- TUBO DI ASPIRAZIONE
- TUBO DI MANDATA
- MANUALE ISTRUZIONI

DETTAGLI



FILTRAZIONE A DUE FASI



STRUTTURA ROBUSTA



RUOTE GRANDI

MATERIALI

- CORPO: GHISA
- ROTORE: ACCIAIO SINTERIZZATO
- PALETTE: TECNOPOLIMERO
- ALBERO: ACCIAIO
- FILTRO: CARTA FILTRANTE ASSORBENTE

FILTROLL