



FUEL MANAGEMENT  
SYSTEMS



DISPENSERS



KITS



POMPE



CONTALITRI



PISTOLE

# FILTROLL

## CARATTERISTICHE

- **FILTRAZIONE A DUE FASI**
- **TUBO SPIRALATO**
- **FACILE DA MANEGGIARE**
- **RUOTE DI GRANDE DIAMETRO**

PIUSI FILTROLL è un innovativo gruppo portatile che assicura la doppia filtrazione completa di qualsiasi tipo di serbatoio, assorbendo acqua e impurità. La robusta struttura carrellata consente all'operatore di spostare facilmente questo gruppo in qualsiasi condizione. È dotato di tubo di aspirazione e valvola di fondo integrata.

### PERFORMANCE

FINO A

**56 L/MIN**

PORTATA

**AC/DC**

VOLTAGGIO

POTENZA

**30μ**

ASSORBIMENTO ACQUA

FILTRAZIONE

**5μ**

IMPURITÀ

FILTRAZIONE



FILTROLL

### PACKAGING

CODICE	PESO		PACKAGING		
	KG	LBS	MM	INCH	PCS/BOX
FO0506000	35	77,2	790X590X590	31,1X23,2X23,2	1
FO050606A	40	88,2	790X590X590	31,1X23,2X23,2	1



FILTRAZIONE



MONITORAGGIO FLUIDI



ARROTOLATORI



ACCESSORI



MERCANDISE

**PIUSI**



ARIA



ANTIGELO



AdBlue®



BIODIESEL



DIESEL



ALIMENTI



BENZINA



GRASSO



KEROSENE



OLIO



ACQUA



LAVAVETRI

## GRAFICO

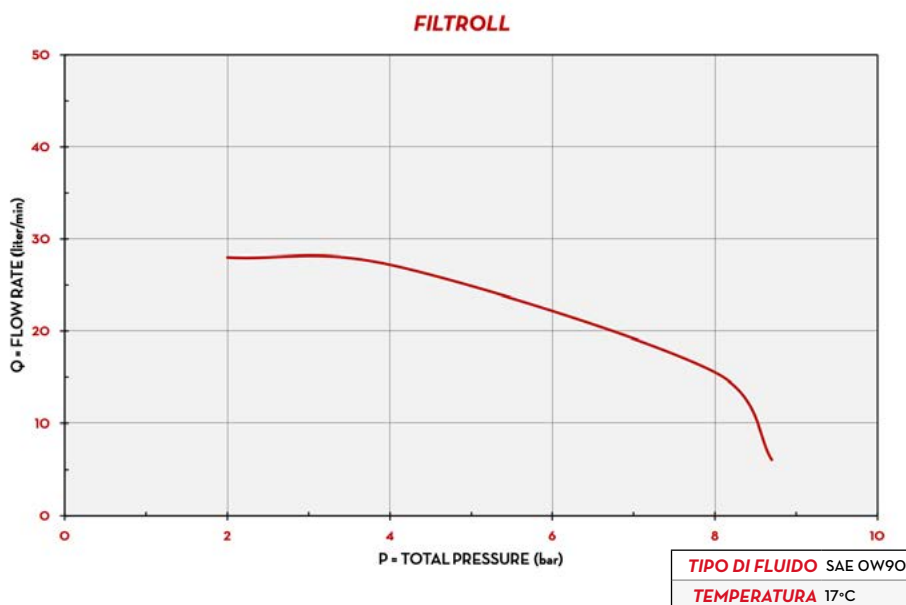

## DENTRO LA SCATOLA

- GRUPPO FILTROLL
- TUBO DI ASPIRAZIONE
- TUBO DI MANDATA
- PISTOLA
- MANUALE ISTRUZIONI

## DETTAGLI



FILTRAZIONE A DUE FASI



FILTRI ACQUA/IMPURITÀ

## DIMENSIONI

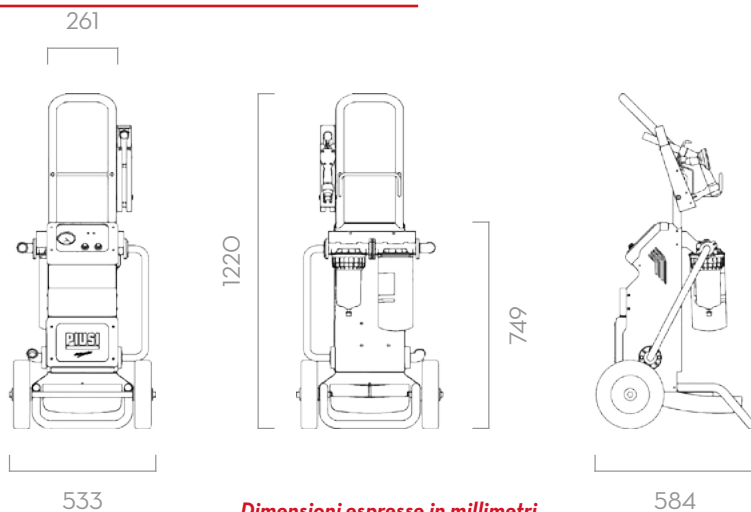

## MATERIALI

- CORPO: GHISA
- ROTORE: ACCIAIO SINTERIZZATO
- PALETTE: TECNOPOLIMERO
- ALBERO: ACCIAIO
- FILTRO: CARTA FILTRANTE ASSORBENTE

## DATI TECNICI

CODICE	DESCRIZIONE	TIPO DI FLUIDO	PORTATA		VOLTAGGIO			PUMP	LUNGH. TUBO	
			L/MIN	GPM	AC V/HZ DC VOLT	POTENZA WATT	AMP. MAX.		TIPO	MANDATA M/FT.
FO0506000	FILTROLL DIESEL	D	56	14,8	230/50-60	350/600	3/6	PANTH. 56	4 / 13,1	3 / 9,8
FO050606A	FILTROLL 12V DIESEL	D	56	14,8	12	300	35	PANTH. DC	4 / 13,1	4 / 13,1

## CARTUCCIA PER FILTRO

CODICE	DESCRIZIONE	MICRO	EFFICIENZA
		μ m	
FO061102A	WATER CAPTOR CART. 150 L/MIN	30	200
FO0611030	CLEAR CAPTOR CARTRIDGE	5	2

## TESTATA DEL FILTRO

F1693400A	FILTER HEAD 70/100LT W/MANOM	-	-
F15744000	CLEAR CAPTOR FILTER HEAD	-	-

DISPONIBILE NELLE VERSIONI 230V/60HZ, 120V/60HZ

**FILTROLL**