



FUEL MANAGEMENT SYSTEMS



DISPENSERS



KITS



POMPE



CONTALITRI



PISTOLE

# EX140



## CARATTERISTICHE

- ELEVATA PORTATA
- CONDIZIONI DI LAVORO GRAVOSE
- FUNZIONAMENTO CONTINUO
- PROTEZIONE TERMICA
- DISPONIBILE VERSIONE UL
- PIEDINI POMPA ESTRAIBILI

La nuovissima linea EX è caratterizzata da un'elevata portata che lavora con un ciclo di funzionamento continuo, ed è stata progettata per essere particolarmente indicata per i veicoli pesanti, cioè per quelle flotte esigenti che necessitano di erogare rapidamente carburanti come benzina, diesel o cherosene.

### PERFORMANCE

FINO A  
**140 L/MIN**

PORTATA

**AC**  
VOLTAGGIO

POTENZA



II 2 G



EX140

LE NOSTRE POMPE SONO CONFORMI ALLA MARCATURA ATEX / IECEx

II	2	G	Ex	d	IIA	T4	Gb
GRUPPO	CATEGORIA	TIPO DI ATMOSFERA ESPLOSIVA	PREFISSO PERMANENTE	METODO DI PROTEZIONE	CLASSE DI GAS	CLASSE DI TEMPERATURA	LIVELLO DI PROTEZIONE DELL'ATTREZZATURA

### PACKAGING

CODICE	PESO		PACKAGING		
	KG	LBS	MM	INCH	PCS/BOX
FO0395010	25	55	240X400X350	9,4X15,7X13,8	1
FO0395020	25	55	240X400X350	9,4X15,7X13,8	1
FO0395030	25	55	240X400X350	9,4X15,7X13,8	1



FILTRAZIONE



MONITORAGGIO FLUIDI



ARROTOLATORI



ACCESSORI



MERCHANDISE



ARIA



ANTIGELO



AdBlue®



BIODIESEL



DIESEL



ALIMENTI



BENZINA



GRASSO



KEROSENE



OLIO



ACQUA



LAVAVETRI

## GRAFICO

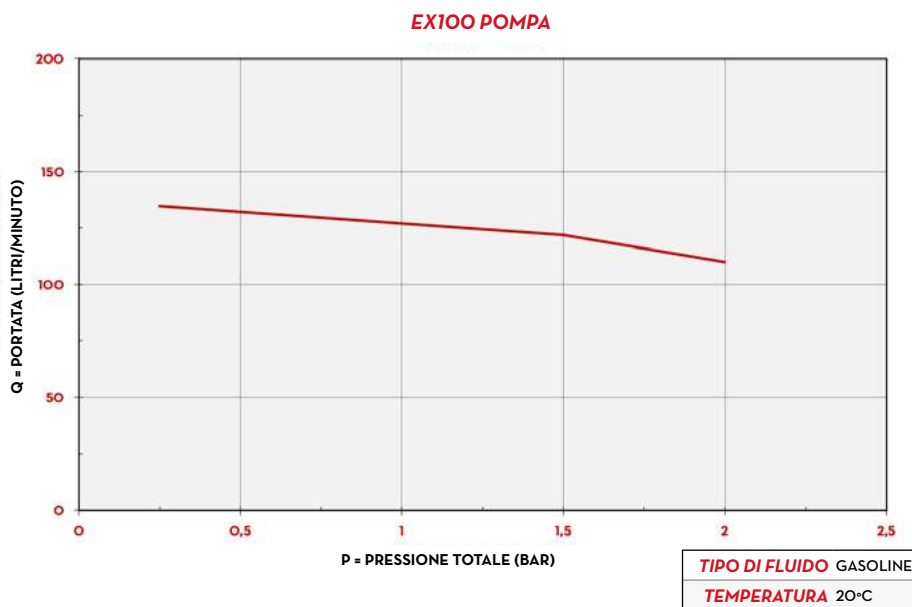

## DIMENSIONI

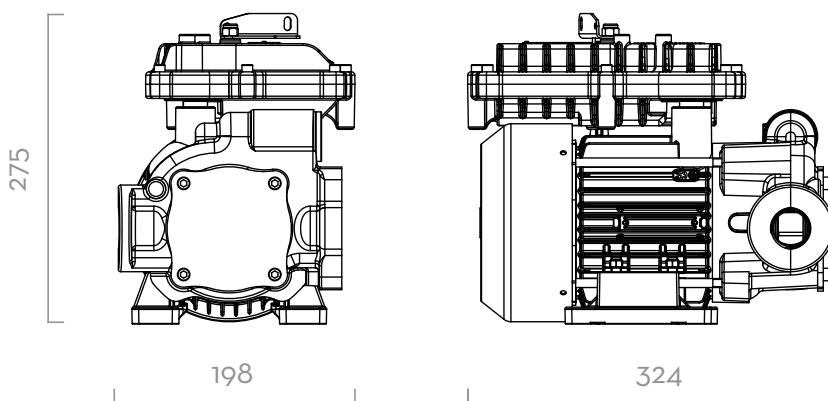

Dimensioni espresse in millimetri

## DENTRO LA SCATOLA

- POMPA EX140
- PIEDINI POMPA
- MANUALE ISTRUZIONI

## DETTAGLI



## MATERIALI

- CORPO: GHISA
- ROTORE: ACCIAIO SINTERIZZATO
- PALETTE: TECNOPOLIMERO
- GUARNIZIONE: VITON
- ALBERO: ACCIAIO



POMPA

- MASSIMO 6M (20FT),
- TUBO DI ASPIRAZIONE Ø 1" MIN,
- MASSIMA ALTEZZA D'ASPIRAZIONE:
  - 2M (7FT) SENZA VALVOLA DI NON RITORNO
  - 4M (14FT) CON VALVOLA DI NON RITORNO



FUSTO

## DATI TECNICI

CODICE	DESCRIZIONE	TIPO DI FLUIDO	PORTATA		VOLTAGGIO			CICLO DI LAVORO CONTINUO	RPM	INGRESSO		OUTLET
			L/MIN	GPM	AC VOLT/HZ	POTENZA WATT	AMP. MAX.			BSP	BSP	
FO0395010	EX 140 230/50	D G K	140	37	230/50	1150	5	SI	1450	1" 1/4	1"	
FO0395020	EX 140 250/50	D G K	140	37	250/50	1125	4,5	SI	1450	1" 1/4	1"	
FO0395030	EX 140 230/60	D G K	140	37	230/60	920	4	SI	1750	1" 1/4	1"	

(\*) SU RICHIESTA È DISPONIBILE CON DIVERSI VOLTAGGIO E FREQUENZA 60 HZ. LA POMPA PUÒ ESSERE UTILIZZATA SOLO CON SEGUENTI FLUIDI: DIESEL, KEROSENE, BENZINA, ALCOOL MISTO BENZINA MAX 15%, AVGAS 100 / 100LL, JET A / A1 - ASPEN 2/4

# EX140



# IECEX Certificate of Conformity

## INTERNATIONAL ELECTROTECHNICAL COMMISSION IEC Certification Scheme for Explosive Atmospheres

for rules and details of the IECEx Scheme visit [www.iecex.com](http://www.iecex.com)

Certificate No.: IECEx UL 19.0065X

Issue No: 0

Certificate history:

Issue No. 0 (2019-06-27)

Status: **Current**

Page 1 of 4

Date of Issue: **2019-06-27**

Applicant: **PIUSI S.p.a.**  
Via Antonio Pacinotti 16A  
I-46029 Suzzara (MN)  
**Italy**

Equipment: **Electric pumps, EX100 and EX140**

*Optional accessory:*

Type of Protection: **Flameproof "db", Constructional Safety "h"**

Marking:  
Ex db h IIA T4 Gb  
-20°C ≤Ta≤ +40°C

*Approved for issue on behalf of the IECEx  
Certification Body:*

Lucy Frieders

*Position:*

Staff Engineer

*Signature:  
(for printed version)*

*Date:*

2019-06-27

1. This certificate and schedule may only be reproduced in full.
2. This certificate is not transferable and remains the property of the issuing body.
3. The Status and authenticity of this certificate may be verified by visiting the [Official IECEx Website](http://www.iecex.com).

Certificate issued by:

**UL LLC**  
333 Pfingsten Road  
Northbrook IL 60062-2096  
United States of America





# IECEX Certificate of Conformity

Certificate No: IECEX UL 19.0065X

Issue No: 0

Date of Issue: **2019-06-27**

Page 2 of 4

Manufacturer: **PIUSI S.p.a.**  
Via Antonio Pacinotti 16A  
I-46029 Suzzara (MN)  
**Italy**

Additional Manufacturing location(s):

This certificate is issued as verification that a sample(s), representative of production, was assessed and tested and found to comply with the IEC Standard list below and that the manufacturer's quality system, relating to the Ex products covered by this certificate, was assessed and found to comply with the IECEX Quality system requirements. This certificate is granted subject to the conditions as set out in IECEX Scheme Rules, IECEX 02 and Operational Documents as amended.

## STANDARDS:

The apparatus and any acceptable variations to it specified in the schedule of this certificate and the identified documents, was found to comply with the following standards:

<b>IEC 60079-0 : 2017</b> Edition:7.0	Explosive atmospheres - Part 0: Equipment - General requirements
<b>IEC 60079-1 : 2014-06</b> Edition:7.0	Explosive atmospheres - Part 1: Equipment protection by flameproof enclosures "d"
<b>ISO 80079-36 : 2016</b> Edition:1.0	Explosive atmospheres - Part 36: Non-electrical equipment for explosive atmospheres - Basic methods and requirements
<b>ISO 80079-37 : 2016</b> Edition:1.0	Explosive atmospheres - Part 37: Non-electrical equipment for explosive atmospheres - Non electrical type of protection constructional safety "c", control of ignition source "b", liquid immersion "k"

*This Certificate **does not** indicate compliance with electrical safety and performance requirements other than those expressly included in the Standards listed above.*

## TEST & ASSESSMENT REPORTS:

*A sample(s) of the equipment listed has successfully met the examination and test requirements as recorded in*

Test Report:

[US/UL/ExTR19.0074/00](#)

Quality Assessment Report:

[DE/TPS/QAR18.0005/01](#)



# IECEX Certificate of Conformity

Certificate No: IECEx UL 19.0065X

Issue No: 0

Date of Issue: 2019-06-27

Page 3 of 4

## Schedule

### EQUIPMENT:

*Equipment and systems covered by this certificate are as follows:*

Electric Pumps model EX100 and EX140 utilised for different combustible hydrocarbon liquids (petrol, diesel and kerosene ) with duty type continuous S1.

Electric motor enclosure is made of aluminium and the pump in cast iron.

**Please see Annex for additional information.**

### SPECIFIC CONDITIONS OF USE: YES as shown below:

- The screws class used for the assembly of explosion-proof enclosures must be of quality higher or equal to 8.8 (ISO 898-1).
- Flameproof joints are not intended to be repaired.
- Fluid temperature range shall be from -20°C to +40°C.



# IECEX Certificate of Conformity

Certificate No: IECEX UL 19.0065X

Issue No: 0

Date of Issue: 2019-06-27

Page 4 of 4

**Additional information:**

**Annex:**

[Annex to IECEX UL 19.0065X Issue 0.pdf](#)



# IECEx Certificate of Conformity

Certificate No.: IECEx UL 19.0065X

Issue No.: 0

Page 1 of 2

## PARAMETERS RELATING TO THE SAFETY

Type	Supply rating	Current	RPM	Duty
EX100	230V 50Hz	4.5 A	1450	Continuous S1
	230V 60Hz	3.8 A	1750	
	250V 50Hz	4 A	1450	
EX140	230V 50Hz	5 A	1450	
	230V 60Hz	4.5 A	1750	
	250V 50Hz	4 A	1450	

## MARKING

		<b>PIUSI</b> Suzzara (MN) Italy	ELECTRIC FUEL PUMP TYPE <b>EX100</b>
DEMKO 19 ATEX 2155 X		Ex db h IIA T4 Gb	L.N.
IECEx UL 19.0065X		Date	
230V 50Hz	4,5 A	1450 rpm	Ta -20° / +40°C
Insulation Class F	Duty CONTINUOUS S1	Q <sub>max</sub> 100 l/m - P <sub>max</sub> 1,8 bar	
⚠ WARNING: Automatic thermal protected motor - not open when energized			

		<b>PIUSI</b> Suzzara (MN) Italy	ELECTRIC FUEL PUMP TYPE <b>EX100</b>
DEMKO 19 ATEX 2155 X		Ex db h IIA T4 Gb	L.N.
IECEx UL 19.0065X		Date	
230V 60Hz	3,8 A	1750 rpm	Ta -20° / +40°C
Insulation Class F	Duty CONTINUOUS S1	Q <sub>max</sub> 100 l/m - P <sub>max</sub> 1,8 bar	
⚠ WARNING: Automatic thermal protected motor - not open when energized			

		<b>PIUSI</b> Suzzara (MN) Italy	ELECTRIC FUEL PUMP TYPE <b>EX100</b>
DEMKO 19 ATEX 2155 X		Ex db h IIA T4 Gb	L.N.
IECEx UL 19.0065X		Date	
250V 50Hz	4 A	1450 rpm	Ta -20° / +40°C
Insulation Class F	Duty CONTINUOUS S1	Q <sub>max</sub> 100 l/m - P <sub>max</sub> 1,8 bar	
⚠ WARNING: Automatic thermal protected motor - not open when energized			



# IECEx Certificate of Conformity

Certificate No.: IECEx UL 19.0065X

Issue No.: 0

Page 2 of 2

		<b>PIUSI</b> Suzzara (MN) Italy		ELECTRIC FUEL PUMP TYPE <b>EX140</b>
		<b>Ex db h IIA T4 Gb</b>		L.N.
<input type="checkbox"/>	DEMKO 19 ATEX 2155 X	IECEx UL 19.0065X		Date <input type="checkbox"/>
230V 50Hz	5 A	1450 rpm	Ta -20° / +40°C	
Insulation Class F		Duty CONTINUOUS S1		Q,max 140 l/m - Pmax 1,8 bar
⚠ WARNING: Automatic thermal protected motor - not open when energized				

		<b>PIUSI</b> Suzzara (MN) Italy		ELECTRIC FUEL PUMP TYPE <b>EX140</b>
		<b>Ex db h IIA T4 Gb</b>		L.N.
<input type="checkbox"/>	DEMKO 19 ATEX 2155 X	IECEx UL 19.0065X		Date <input type="checkbox"/>
230V 60Hz	4,5 A	1750 rpm	Ta -20° / +40°C	
Insulation Class F		Duty CONTINUOUS S1		Q,max 140 l/m - Pmax 1,8 bar
⚠ WARNING: Automatic thermal protected motor - not open when energized				

		<b>PIUSI</b> Suzzara (MN) Italy		ELECTRIC FUEL PUMP TYPE <b>EX140</b>
		<b>Ex db h IIA T4 Gb</b>		L.N.
<input type="checkbox"/>	DEMKO 19 ATEX 2155 X	IECEx UL 19.0065X		Date <input type="checkbox"/>
250V 50Hz	4 A	1450 rpm	Ta -20° / +40°C	
Insulation Class F		Duty CONTINUOUS S1		Q,max 140 l/m - Pmax 1,8 bar
⚠ WARNING: Automatic thermal protected motor - not open when energized				

**⚠ WARNING ⚠**  
 DO NOT OPEN WHEN AN  
 EXPLOSIVE ATMOSPHERE IS  
 PRESENT  
 SEE INSTALLATION  
 INSTRUCTION DOCUMENT

**WARNING :** DO NOT OPEN WHEN AN EXPLOSIVE ATMOSPHERE IS PRESENT  
 SEE INSTALLATION INSTRUCTION DOCUMENT