



FUEL MANAGEMENT  
SYSTEMS



DISPENSERS



KITS



POMPE



CONTALITRI



PISTOLE

# E300

## CARATTERISTICHE

- **POMPA A ELEVATA PORTATA**
- **STRUTTURA ROBUSTA**
- **CONDIZIONI DI LAVORO GRAVOSE**
- **IP44**

PIUSI E300 è una pompa centrifuga adatta a tutte le situazioni in cui sono richieste portate elevate. Si tratta quindi dell'attrezzatura ideale per il rabbocco e il travaso del diesel dai fusti. Viene fornita con una valvola di non ritorno incorporata nella bocca aspirante per evitare l'effetto sifone, garantendo al tempo stesso il ri-adesamento automatico.

### PERFORMANCE

FINO A

**550 L/MIN**

PORTATA

FUNZIONAMENTO

**AC**  
**CONTINUO**

POTENZA

**1,8 BAR**

MAX

PRESSIONE D'ESERCIZIO

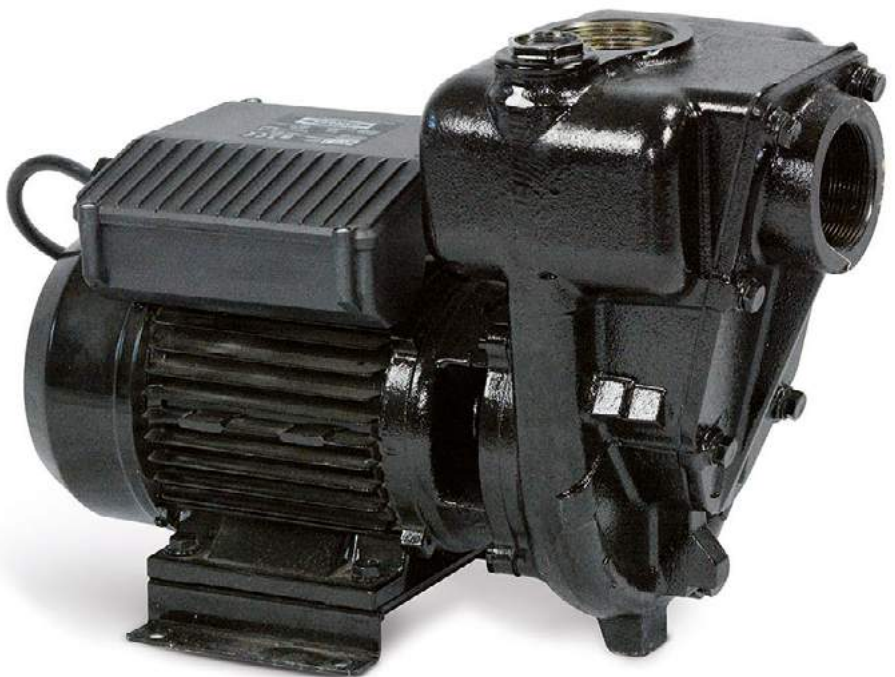

E300



### PACKAGING

CODICE	PESO		PACKAGING		
	KG	LBS	MM	INCH	PCS/BOX
FO0321000	28	61,7	220X420X330	8,7X16,5X13	1



FILTRAZIONE



MONITORAGGIO FLUIDI



ARROTOLATORI



ACCESSORI



MERCHANDISE



ARIA



ANTIGELO



AdBlue®



BIODIESEL



DIESEL



ALIMENTI



BENZINA



GRASSO



KEROSENE



OLIO



ACQUA



LAVAVETRI

## GRAFICO



TIPO DI FLUIDO DIESEL

TEMPERATURA 10°C

## DIMENSIONI

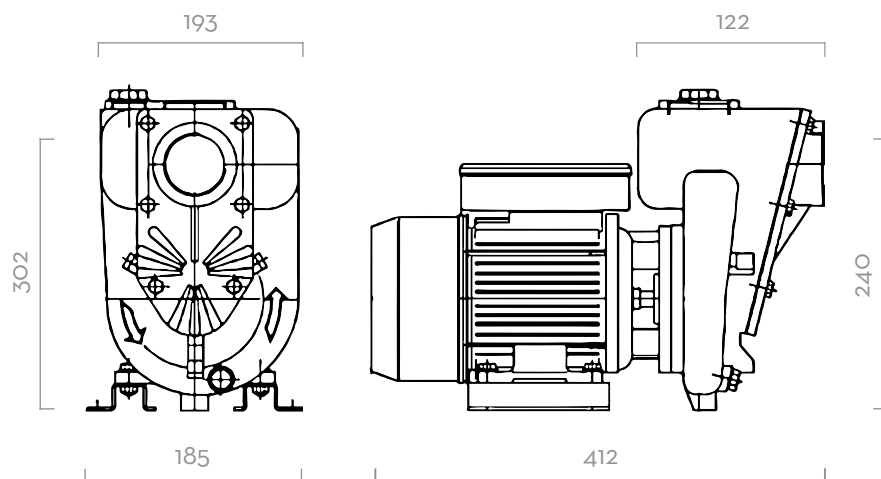

Dimensioni espresse in millimetri

## DENTRO LA SCATOLA

- POMPA E300
- MANUALE ISTRUZIONI

## DETTAGLI



GIRANTE APERTA



COLLEGAMENTI IN/OUT 2"



SUPPORTO STABILE

## MATERIALI

- CORPO: GHISA
- ROTORE: ACCIAIO SINTERIZZATO
- PALETTE: RESINA ACETALICA
- GUARNIZIONE: VITON
- ALBERO: ACCIAIO

## DATI TECNICI

CODICE	DESCRIZIONE	TIPO DI FLUIDO	PORTATA		VOLTAGGIO			RPM	INGRESSO
			L/MIN	GPM	AC VOLT/HZ	POTENZA WATT	AMP. MAX.		OUTLET
FO0321000	E 300	D	550	132	230/50	1500	9,2	2580	BSP 2"

# E300