



FUEL MANAGEMENT  
SYSTEMS



DISPENSERS



KITS



POMPE



CONTALIBRI



PISTOLE

# E140

## CARATTERISTICHE

- FUNZIONAMENTO CONTINUO
- ELEVATA PORTATA
- POMPA PER CONDIZIONI DI LAVORO GRAVOSE
- DESIGN ROBUSTO

La pompa E140 per travaso diesel è versatile e adatta a diversi settori industriali tra cui automotive, agricoltura, trasporti, garage e costruzioni. La pompa E140 volumetrica autoadescante a palette per il travaso del diesel ha una tenuta elevata ed è affidabile in condizioni di utilizzo a basse temperature. Con la sua struttura solida e resistente, E140 è una pompa per travaso diesel di facile installazione, adatta per l'uso in dispenser di diesel e sistemi fissi di travaso carburante, così come per altre applicazioni industriali. La struttura compatta in ghisa rende l'elettropompa E140 il sistema perfetto per prestazioni e affidabilità.

### PERFORMANCE

FINO A  
**140 L/MIN**

PORTATA

**AC**  
VOLTAGGIO

POTENZA



E140



### PACKAGING

CODICE	PESO		PACKAGING			N. BOX / EUROPALLET	
	KG	LBS	MM	INCH	PCS/BOX	✈	
FO0395060	18	40	350X250X300	14X10X12	1	60	72
FO0395050	18	40	350X250X300	14X10X12	1	60	72



FILTRAZIONE



MONITORAGGIO FLUIDI



ARROTOLATORI



ACCESSORI



MERCANDISE



ARIA



ANTIGELO



AdBlue®



BIODIESEL



DIESEL



ALIMENTI



BENZINA



GRASSO



KEROSENE



OLIO



ACQUA



LAVAVETRI

## GRAFICO

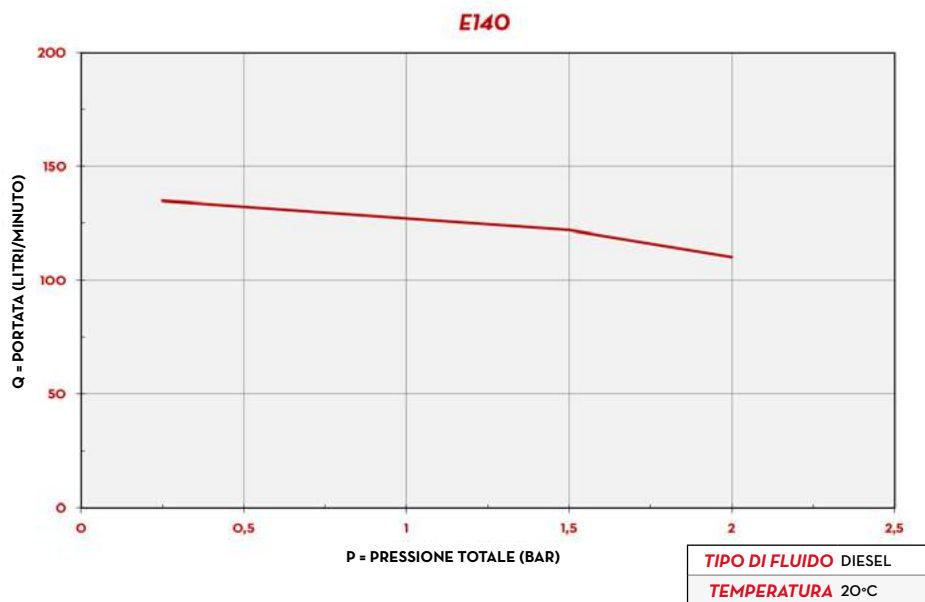

## DIMENSIONI

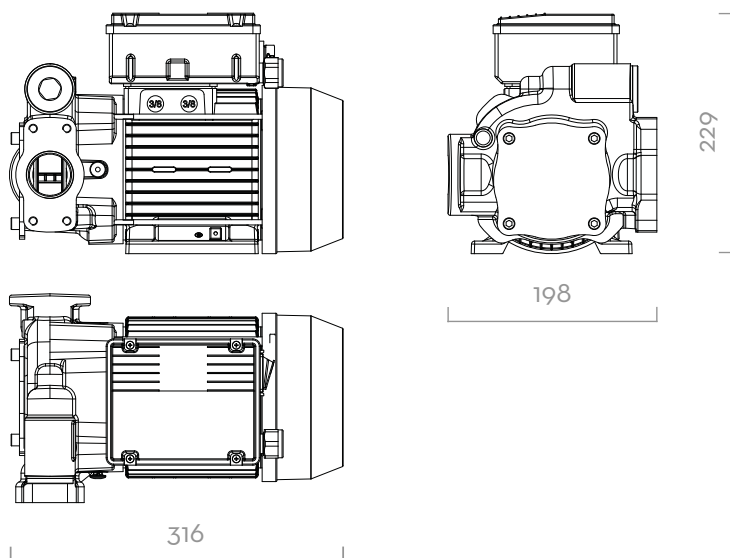

Dimensioni espresse in millimetri

## DENTRO LA SCATOLA

- POMPA E140
- MANUALE ISTRUZIONI

## DETTAGLI



## MATERIALI

- CORPO: GHISA
- ROTORE: ACCIAIO SINTERIZZATO
- PALETTE: TECNOPOLIMERO
- GUARNIZIONE: VITON
- ALBERO: ACCIAIO

## DATI TECNICI

CODICE	DESCRIZIONE	TIPO DI FLUIDO	PORTATA		VOLTAGGIO			CICLO DI LAVORO CONTINUO	RPM	INLET	OUTLET
			L/MIN	GPM	AC VOLT/HZ	POTENZA WATT	AMP. MAX.			BSP	
FO0395060	E 140 250/50	D	140	37	250/50	1150	5	S1	1450	1" 1/4	1"
FO0395050	E 140 230/50	D	140	37	230/50	1150	5	S1	1450	1" 1/4	1"

# E140