



FUEL MANAGEMENT
SYSTEMS



DISPENSERS



KITS



POMPE



CONTALITRI



PISTOLE

BP3000

CARATTERISTICHE

- VERSATILE
- APPLICAZIONI ON BOARD
- COMPATIBILITÀ EMC
- RESISTENTE ALLE VIBRAZIONI
- IP55

PIUSI BP3000 è una pompa autoadescante a palette di lunga durata. Potente, versatile e compatta, è dotata di una valvola di by-pass integrata. Disponibile nelle versioni 12 V e 24 V, rappresenta il fulcro della gamma di pompe PIUSI per applicazioni on board, in particolare nell'industria delle macchine movimento terra e fuoristrada.



BP3000 INLINE



BP3000

PERFORMANCE

FINO A

50 L/MIN

PORTATA

DC

VOLTAGGIO

POTENZA

30 MIN

CICLO DI LAVORO

FINO A

4MT

AUTO-ADESCANTE

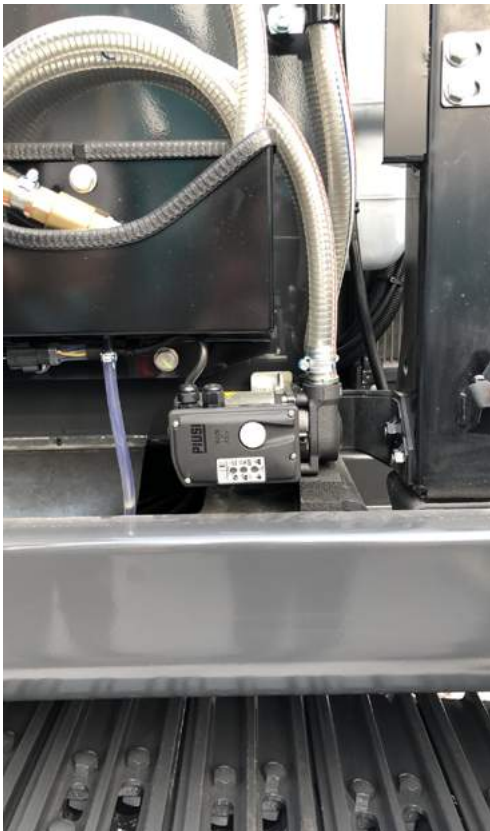

PACKAGING

CODICE	PESO		PACKAGING		
	KG	LBS	MM	INCH	PCS/BOX
FO0342000	3,5	7,9	200X120X140	7,9X4,7X5,5	1
FO0347000	3,5	7,9	200X120X140	7,9X4,7X5,5	1
FO0357000	3,5	7,9	200X120X140	7,9X4,7X5,5	1
FO0357500	3,5	7,9	200X120X140	7,9X4,7X5,5	1
FO0358000	3,5	7,9	200X120X140	7,9X4,7X5,5	1
FO0358500	3,5	7,9	200X120X140	7,9X4,7X5,5	1



FILTRAZIONE



MONITORAGGIO FLUIDI



ARROTOLATORI



ACCESSORI



MERCHANDISE



ARIA



ANTIGELO



AdBlue®



BIODIESEL



DIESEL



ALIMENTI



BENZINA



GRASSO



KEROSENE



OLIO



ACQUA



LAVAVETRI

GRAFICO

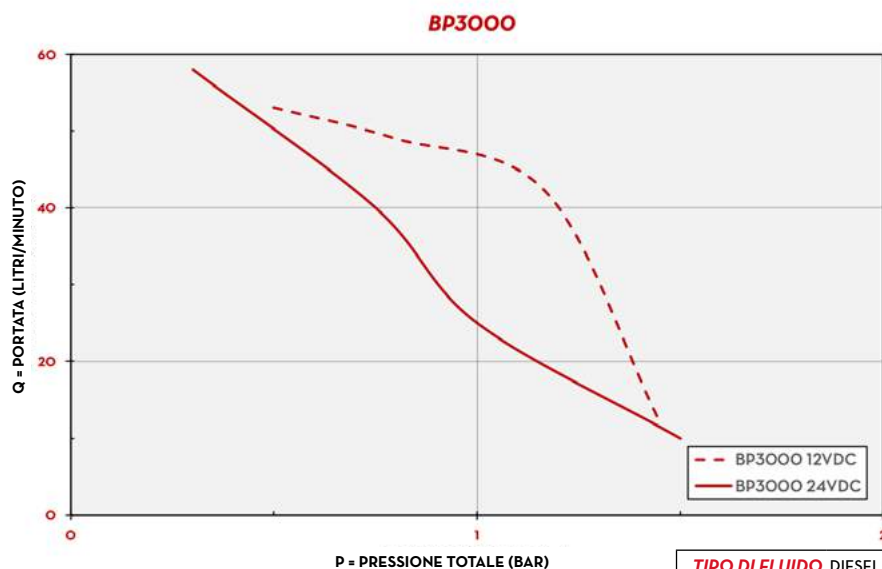

TIPO DI FLUIDO DIESEL

TEMPERATURA 20°C

DIMENSIONI

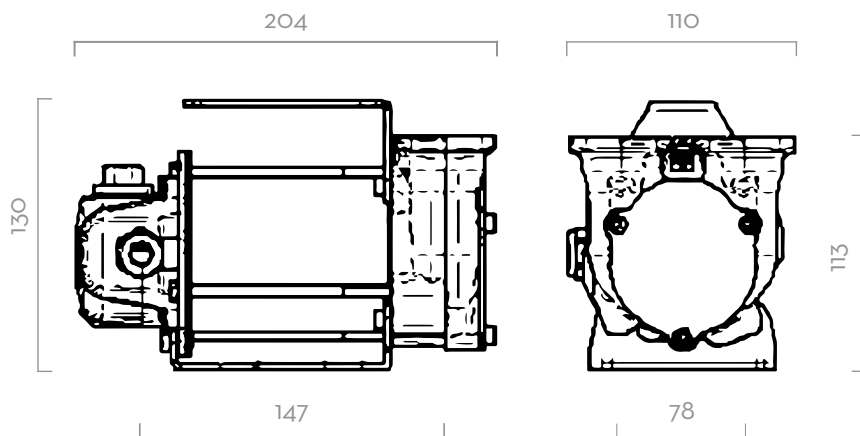

Dimensioni espresse in millimetri

DENTRO LA SCATOLA

- POMPA BP3000
- MANUALE ISTRUZIONI

DETTAGLI



KIT COLLEGAMENTO (pag. 124)

MATERIALI

- CORPO: GHISA
- ROTORE: ACCIAIO SINTERIZZATO
- PALETTE: RESINA ACETALICA
- GUARNIZIONE: NBR
- ALBERO: ACCIAIO



BOMBA

- MÁX. 6 M (20 FT),
- MANGUERA DE SUCCIÓN Ø 1" MÍN.,
- ALTURA MÁX. DE SUCCIÓN:
- 2M (7FT) SIN VÁLVULA ANTIRRETORNO
- 4M (14FT) CON VÁLVULA ANTIRRETORNO



DEPÓSITO

DATI TECNICI

CODICE	DESCRIZIONE	TIPO DI FLUIDO	PORTATA		VOLTAGGIO			CICLO DI LAVORO MINUTI	RPM	PORTE FILETTATE BSP	PRESSIONE MASSIMA D'ESERCIZIO BAR
			L/MIN	GPM	DC VOLT	POTENZA WATT	AMP. MAX.				
FO0342000	BP3000 12V	D	50	13	12	300	24	30	2900	-	1,5
FO0347000	BP3000 24V	D	50 / 30	13 / 6	24/12	310 / 80	13 / 6,5	30	2900 / 1500	-	1,5
FO0357000	BP3000 12V INLINE	D	50	13	12	300	24	30	2900	-	1,5
FO0357500	BP3000 12V INLINE 3/4' BSP	D	50	13	12	300	24	30	2900	3/4"	1,5
FO0358000	BP3000 24V INLINE	D	50 / 30	13 / 6	24/12	310 / 80	13 / 6,5	30	2900 / 1500	-	1,5
FO0358500	BP3000 24V INLINE 3/4' BSP	D	50 / 30	13 / 6	24/12	310 / 80	13 / 6,5	30	2900 / 1500	3/4"	1,5

BP3000