

Turbine Series

900FH and 1000FH Fuel Filter/Water Separators

Instruction Part Number 12960 Rev E



Turbine Series filters protect precision engine components from dirt, rust, algae, asphaltines, varnishes, and especially water, which is prevalent in engine fuels. They remove contaminants from fuel using the following legendary three stage process:

Stage 1 - Separation

As fuel enters the assembly, it moves through the centrifuge and spins off large solids and water droplets, which are heavier than fuel, and fall to the bottom of the collection bowl.

Stage 2 - Coalescing

Small water droplets bead-up on the surface of the conical baffle and cartridge filter. When heavy enough, they too fall to the bottom of the collection bowl.

Stage 3 - Filtration

Proprietary Aquabloc® cartridge filters repel water and remove contaminants from fuel down to 2 micron (nominal). Aquabloc cartridge filters are waterproof and effective longer than water absorbing filters.



Getting Started

The following customer supplied materials should be on-hand before beginning installation.

- Shop Towels
- Diesel Fuel (about 1 gallon)
- Thread Sealant (no thread tapes)
- Parker Super O-Lube (RK 31605) or equivalent
- Fuel Hose
- Mounting Hardware (3/8" or M10 fasteners)
- Inlet/Outlet Fittings

Contact Information

Parker Hannifin Corporation
Racor Division
P.O. Box 3208
3400 Finch Road
Modesto, CA 95353

phone 800 344 3286
209 521 7860

fax 209 529 3278
racor@parker.com

parker.com/racor



Mounting Information

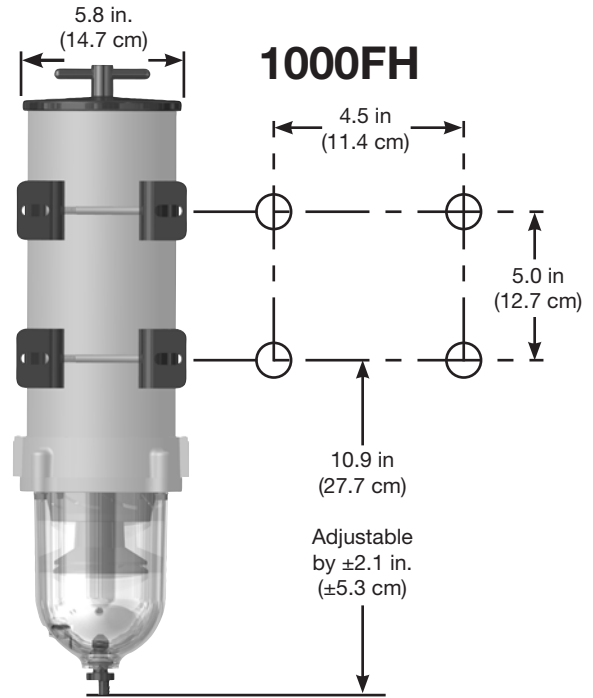
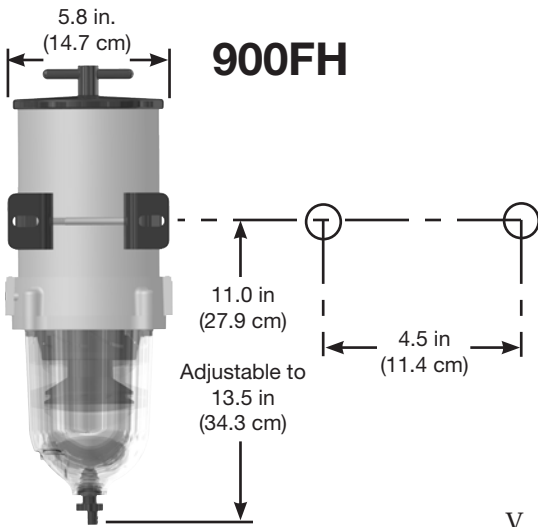

Notes:

1. Mount filter assembly as close to vertical (V) as possible. Do not exceed 10° from vertical or the assembly may not function properly.
2. Fastener size is 3/8" (M10) for mounting brackets.

Installation Diagram

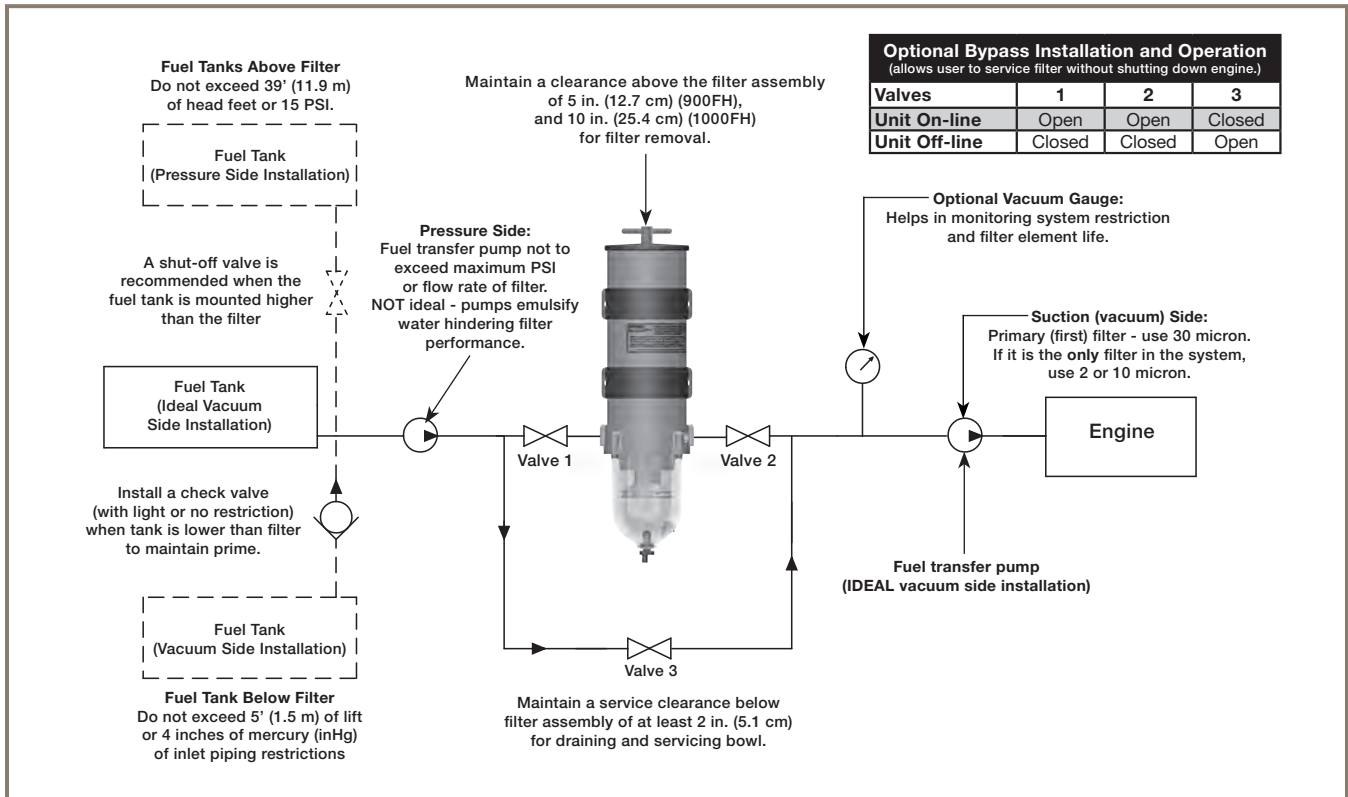

Installation Instructions

Adjustable, one-piece clamp-type mounting brackets (with grade 5 fasteners) are included for ensured durability. The 900FH uses one mounting bracket and 1000FH uses two mounting brackets, both can be adjusted for a secure fit.

Positioning Filter

- Install the Turbine Series filter on the vacuum side of the fuel transfer pump for optimum water separating efficiency.

Note: See Installation Diagram

- Keep fuel line restrictions to a minimum. Locate the filter assembly between the horizontal planes of the bottom of the fuel tank and the inlet of the fuel pump, if possible. If filter is installed in an application where the fuel tank is higher than the filter, a shut-off valve must be installed between the tank and the filter assembly INLET. This will be used when servicing the replacement filter.

Before Installation

- Obtain good ventilation and lighting.
- Maintain a safe working environment.
- The engine must be off for installation.
- DO NOT smoke or allow open flames near the installation.

Installing Filter

- Completely remove any vacuum side filters in the fuel line between the fuel tank and the fuel pump. This is where the filter assembly will be mounted. Leaving these filters in place will add to the fuel line restriction. Filter heads cast into the engine, or that are non-removable, or hard-piped, should be serviced with a new filter and left in place.
- Keep fuel flow restriction values to a minimum. Always use the maximum size fuel hose possible. Do not make sharp bends with flexible fuel hose as kinks may occur. Avoid the use

of two 45° elbow fittings where one 90° elbow will work.

- When routing hose, avoid surfaces that move, have sharp edges, or get hot (such as exhaust piping).

Priming Instructions

1. Remove T-handle and lid from top of filter.
2. Fill filter with clean fuel.
3. Lubricate lid gasket and T-handle O-ring with clean fuel or motor oil.
4. Replace lid and T-handle and tighten snugly by hand only—**do not use tools**.
5. If applicable, refer to equipment Operator's Service Manual to complete fuel priming procedure.
6. Start engine and check for fuel system leaks. Correct as necessary with engine off and pressure relieved from filter assembly.

Service Instructions

Draining Water

Frequency of water draining is determined by the contamination level of fuel. Inspect or drain collection bowl of water daily or as necessary. Collection bowl must be drained before contaminants reach the top of the turbine or when the Water Detection Module (optional) indicates a drain is required.

Vacuum Side Applications

1. Close inlet valve (or valve #1) and open self-venting drain on bottom of bowl.
2. Close drain after all water and contaminants have been evacuated. DO NOT leave drain open too long as it will eventually completely drain the entire filter of water AND fuel.
3. Follow **Priming Instructions**.

Pressure Side Applications

1. Open self-venting drain on bottom of bowl. Head pressure will push any water and contaminants out of drain while keeping filter primed.
2. Close drain after all water and contaminants have been evacuated. DO NOT leave drain open too long as it will eventually completely drain entire filter of water AND fuel, and possibly drain entire tank.

Element Replacement

Frequency of filter replacement is determined by the contamination level of the fuel. Replace filter every 10,000 miles, every 500 hours, every other oil change, when vacuum gauge (optional) reads between 6 to 10 inches of mercury (inHg), if power loss is noticed, or annually, whichever occurs first.

Note: always carry extra replacement filters as one tankful of excessively dirty fuel can plug a filter.

1. Bypass filter assembly with bypass valves, if applicable.

2. Remove T-handle and lid.
3. Remove filter by holding bail handles and slowly pulling upward with a twisting motion. Dispose of properly.
4. Replace old lid gasket and T-handle O-ring with new seals (supplied with new filter). Lubricate both seals with clean motor oil or diesel fuel before installation.
5. Refer to **Priming Instructions** otherwise, fill filter with clean fuel, then replace lid and T-handle and tighten snugly by hand only—**do not use tools**.



Note: above ground tanks or transfer pump applications may use head pressure to prime filter.

Installing Optional In-Filter Heater

Please read and understand all instructions prior to installation.

The in-filter heater option is a cold weather starting aid with an internal automatic thermostat that turns the heater ON when the fuel temperature drops below 50°F (10°C) and turns OFF when the fuel reaches 80°F (27°C). Heat is supplied in the filter assembly just below the replacement filter to melt wax crystals and allow fuel to pass through the filter for quick, easy starting. The 325 watt heater is operated by turning the ignition switch ON for a minimum of five minutes prior to starting the engine.

HEATER WIRING INSTALLATION

Caution! Please read carefully before beginning installation. See schematic on next page.

1. Never power up the heater if there is no fuel in the Racor

filter, **severe damage** may result to the heater and filter assembly.

2. During equipment or vehicle servicing, always ensure power to the Racor heater is turned off. We recommend the installation of a customer-supplied power control switch (see electrical schematic).
3. Check contaminant collection bowl daily for accumulated water. Water is heavier than diesel fuel and will fall to the bottom of the bowl. Drain water before the level reaches the bottom of the turbine centrifuge. Do not allow water to rise to the level of the heater.
4. Ensure wiring installation diagram is closely followed and the proper safety fuse is used. If a fuse should fail, determine the cause and correct it before installing a new fuse and using the heater again.
5. Exterior wiring connections should be soldered, crimped

and sealed for protection against shorting.

6. Route wires in protected locations, away from hot or moving surfaces and places that could expose them to chemical contact or environmental debris.
7. Inspect all wiring and connections for unsafe conditions annually or every 12,000 miles, whichever occurs first.
8. Study the wiring schematic before starting. Due to the power consumption of the heater (12 vdc = 27 amps, 24 vdc = 13.5 amps) an external relay is required. Racor offers relay kits for this application; refer to the Heater Relay Kit Selection Guide, below. Racor Relay kits include instructions on how to attach them to the Racor heater.

See schematic on next page.

Racor Heater Relay Kit Information

Recommended Racor Heater Relay Kit		
Heater Kits	Heater In Use	Use Kit Number
RK11-2016 12 VDC 325 Watts 27 Amps	Single (1)	RK 11861
	Dual (2)	RK 19490-12
RK11-2015 24 VDC 325 Watts 13.5 Amps	Single (1)	RK 11862
	Dual (2)	RK 19490-24



Note - Racor heater relay kits are ordered separately.

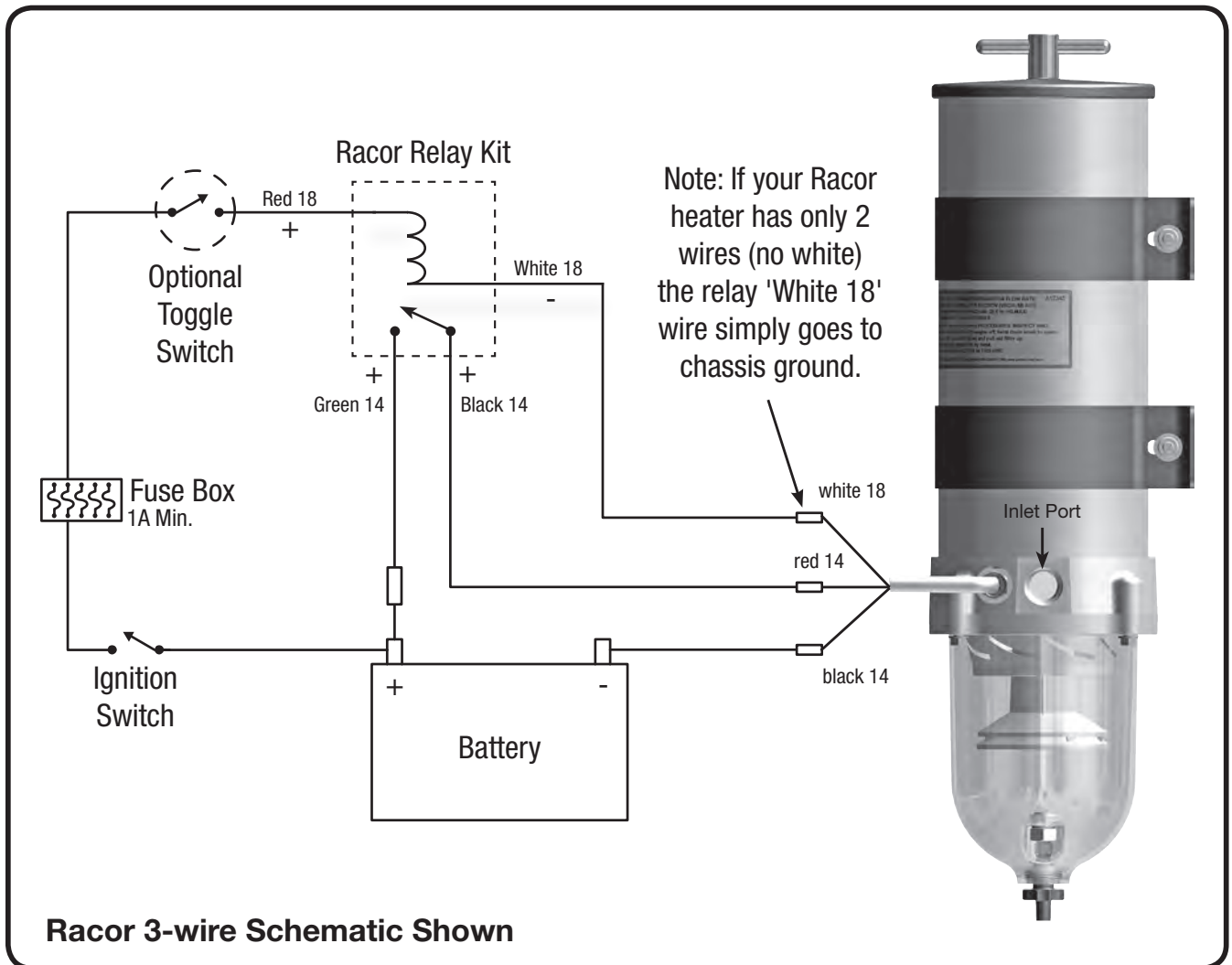

Specifications

900FH



	900FH
Maximum Flow Rate:	90 GPH (341 LPH)
Port Size	7/8" -14 UNF (SAE J1926) (female threads)
Min. Service Clearance: Above Assembly Below Assembly	7.5 in. (19.1 cm) 2.0 in (5.1 cm)
Replacement Filter: (2 micron) (10 micron) (30 micron)	(1 Per Assembly) New: 2040N-02 (Old: 2040SM-OR) New: 2040N-10 (Old: 2040TM-OR) New: 2040N-30 (Old: 2040PM-OR)
Height	17.0 in. (43.2 cm)
Depth	7.0 in. (17.8 cm)
Width	6.0 in. (15.2 cm)
Weight (dry)	6.0 lb (2.7 kg)
Clean Pressure Drop	0.30 PSI (0.021 bar)
Maximum Pressure¹	15 PSI (1.03 bar)
Water In Bowl Capacity:	10.3 oz (305 ml)
Available Options: (water detection kit)² (12 or 24 vdc heater)² (vacuum gauge) (12 or 24 vdc primer pump)	Yes Yes Yes Yes
Water Removal Efficiency	99%
Ambient Temperature Range	-40° to +255°F (-40° to +124°C)
Maximum Fuel Temperature	190°F (88°C)
¹ Pressure installations are applicable up to the maximum PSI shown. Vacuum installations are recommended. ² Not for use on gasoline applications. Note: Units with 1/2" NPT ports are available, contact the factory.	

Replacement Parts

900FH

	Part No.	Description
1.	RK 11-1945	T-handle and O-ring Kit (includes A)
2.	RK 11-1927-01	Lid Kit (includes B)
3.	New: 2040N-02 Old: 2040SM-OR	Replacement Filter (2 Micron) (includes A & B)
	New: 2040N-10 Old: 2040TM-OR	Replacement Filter (10 Micron) (includes A & B)
	New: 2040N-30 Old: 2040PM-OR	Replacement Filter (30 Micron) (includes A & B)
4.	RK 11-2016	12 vdc, Heater Body/Feed-thru Kit (includes A, B, & 6)
	RK 11-2015	24 vdc, Heater Body/Feed-thru Kit (includes A, B, & 6)
5.	RK 11815-103	Mounting Bracket Kit
6.	RK 19663	3-wire Feed-thru Heater Assembly Kit
	RK 11-1679	Body Feed-thru Plug Kit
7.	RK 11-2009	Kit, Body/Housing/Return Tube (includes B (3 pcs) & G)
8.	RK 11-1939	Conical Baffle and Turbine Centrifuge Kit (includes B, C, D, & E)
9.	RK 11-1938	See-thru Bowl with Drain and Plug Kit (includes B, F, & 10)
10.	RK 32204	Water Sensor Kit
11.	RK 20126	Bowl Plug Kit
12.	RK 11037A	Bowl Ring (includes B & G)
G.	RK 11542	Cap Screw Kit
Additional Parts (not shown)		
	RK 11-1952	Complete Seal Service Kit

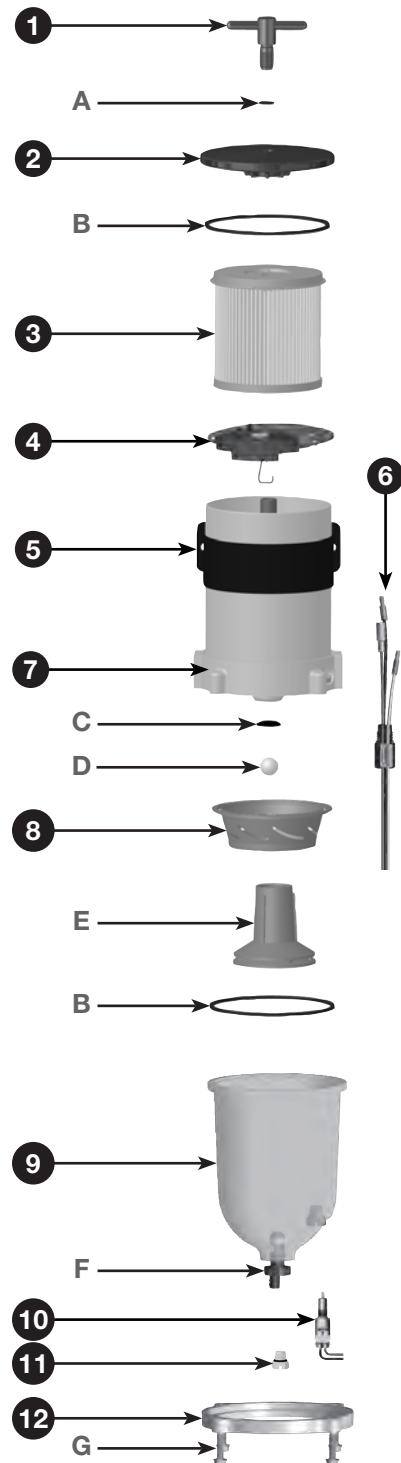

Specifications

1000FH



	1000FH
Maximum Flow Rate:	180 GPH (681 LPH)
Port Size	7/8"-14 UNF (SAE J1926) (female threads)
Minimum Service Clearance: (Above Assembly) (Below Assembly)	10.0 in. (25.4 cm) 2.0 in. (5.1 cm)
Replacement Filter: (2 micron) (10 micron) (30 micron)	(1 Per Assembly) New: 2020N-02 (Old: 2020SM-OR) New: 2020N-10 (Old: 2020TM-OR) New: 2020N-30 (Old: 2020PM-OR)
Height	22.0 in. (55.9 cm)
Depth	7.0 in. (17.8 cm)
Width	6.0 in. (15.2 cm)
Weight (dry)	10.0 lb (4.5 kg)
Clean Pressure Drop	0.43 PSI (0.03 bar)
Maximum Pressure¹	15 PSI (1.03 bar)
Water In Bowl Capacity:	10.3 oz (305 ml)
Available Options: (water detection kit)² (12 or 24 volt dc heater)² (vacuum gauge) (12 or 24 vdc primer pump)	Yes Yes Yes Yes
Water Removal Efficiency	99%
Ambient Temperature Range	-40° to +255°F (-40° to +124°C)
Maximum Fuel Temperature	190°F (88°C)
¹ Pressure installations are applicable up to the maximum PSI shown. Vacuum installations are recommended. ² Not for use on gasoline applications.	

Replacement Parts

1000FH

	Part No.	Description
1.	RK 11-1945	T-handle and O-ring Kit (includes A)
2.	RK 11-1927-01	Lid Kit (includes B)
3.	New: 2020N-02 Old: 2020SM-OR	Replacement Filter (2 Micron) (includes A & B)
	New: 2020N-10 Old: 2020TM-OR	Replacement Filter (10 Micron) (includes A & B)
	New: 2020N-30 Old: 2020PM-OR	Replacement Filter (30 Micron) (includes A & B)
4.	RK 11-2016	12 vdc, Heater/Body Feed-thru Kit (includes A, B, & 6)
	RK 11-2015	24 vdc, Heater/Body Feed-thru Kit (includes A, B, & 6)
5.	RK 11815-103	Mounting Bracket Kit
6.	RK 19663	3-wire Feed-thru Heater Assembly Kit
	RK 11-1679	Body Feed-thru Plug Kit
7.	RK11-2010	Kit, Body/Housing/Return Tube (includes B (3 pcs) & G)
8.	RK 11-1939	Conical Baffle and Turbine Centrifuge Kit (includes B, C, D, & E)
9.	RK 11-1938	See-thru Bowl with Drain and Plug Kit (includes B, F, & 10)
10.	RK 32204	Water Sensor Kit
11.	RK 20126	Bowl Plug Kit
12.	RK 11037A	Bowl Ring (includes B & G)
G.	RK 11542	Cap Screw Kit
Additional Parts (not shown)		
	RK 11-1952	Complete Seal Service Kit

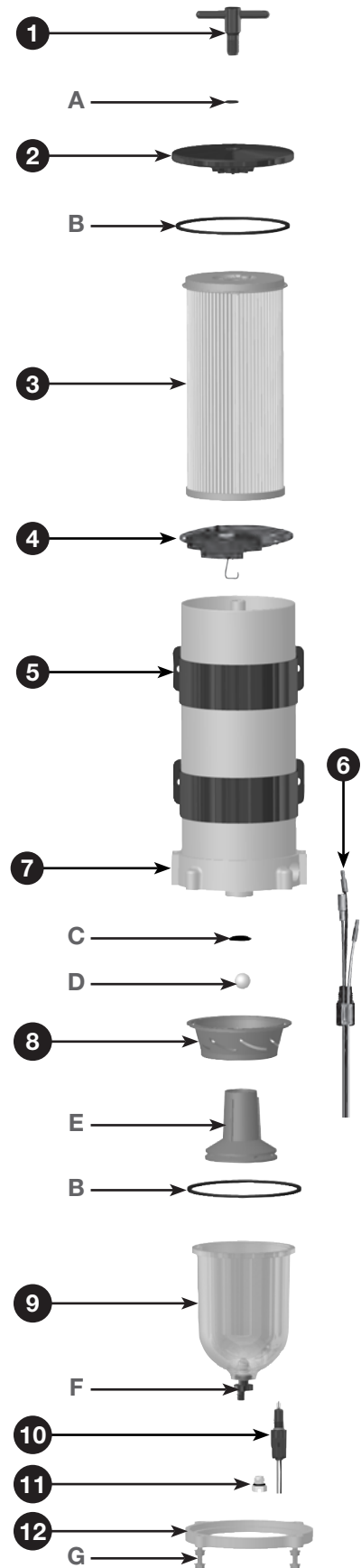

Troubleshooting

Damaged, worn, or dirty seals will allow air ingestion. Inspect and replace all seals as needed. Clean the sealing surfaces of dirt or debris every time the filter is replaced.

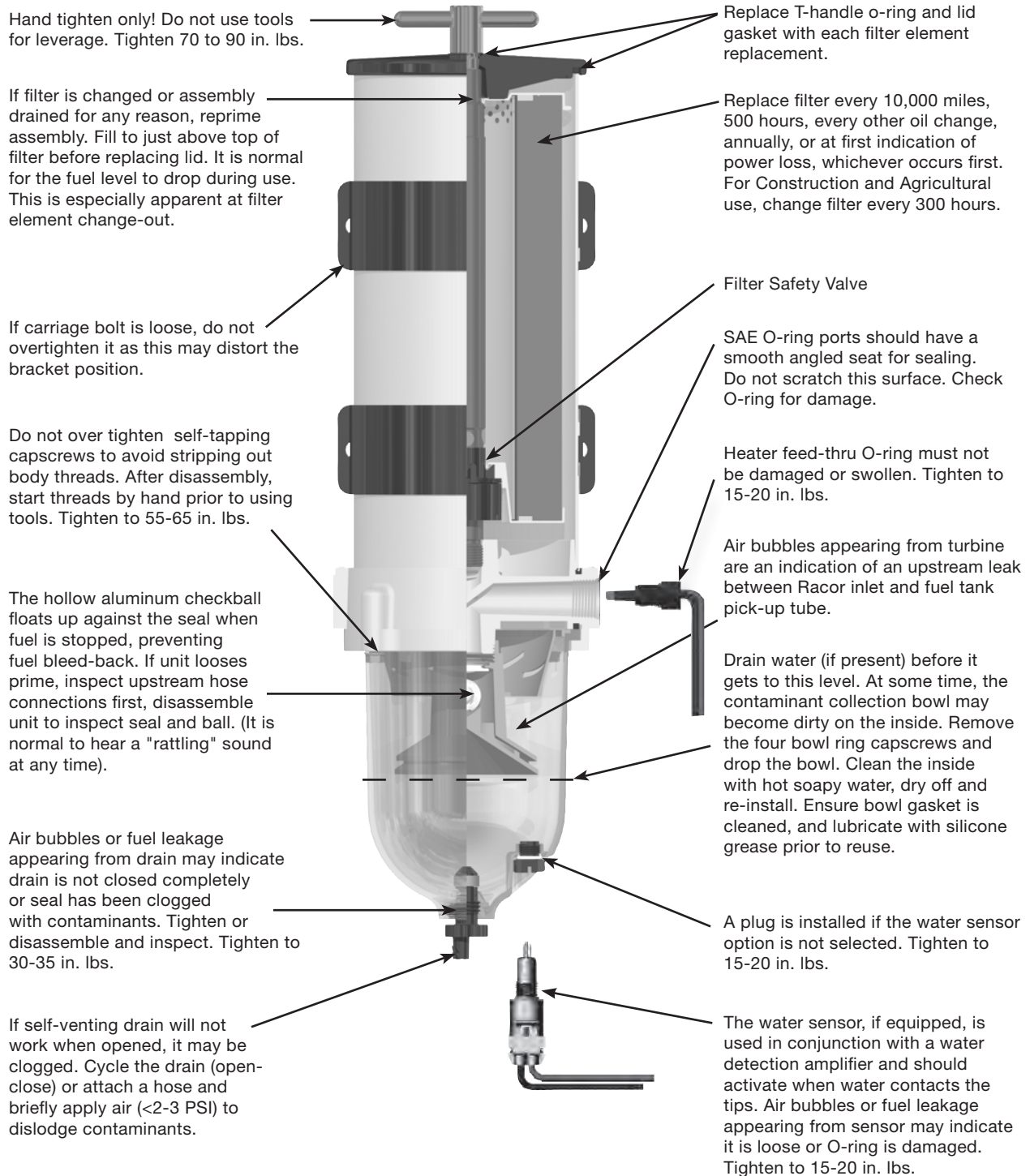

Troubleshooting

Note - Correct external fuel leaks immediately! These conditions will result in reduced engine performance such as: hard starting, stalling, reduced power, and other associated problems.

New filter installations must be filled with fuel and fuel system must be adequately primed following the **engine manufacturer's recommendations**, if applicable. Existing installation difficulties are usually associated with improper priming procedures or damage to the unit or fuel system. The result is either internal air suction or external fuel leakage. Diagnosis should be in these following steps:

1. Check fuel tank level and make sure any fuel delivery valves are in open position, as applicable.
2. Ensure T-handle, bowl fasteners, and fuel fittings are tight. Also verify that bowl drain is closed.
3. If filter is new, check potential restriction at fuel tank draw tube. An in-tank strainer may be plugged.

Correct Application - It is very important that filter is not 'under specified' for the application. The maximum fuel flow rating of filter must not be exceeded and engine manufactures maximum fuel inlet restriction, must not be exceeded. Doing so will reduce efficiency and de-gas (pull air from) fuel.

Filter - Replacement filters are available in 2, 10, and 30 micron ratings. Filtration needs are based on application, fuel quality, maintenance schedules, and operating climates. A simple rule to remember is - the finer

the filtration, the more frequent the filter change. Always carry extra replacement filters with your equipment as one tankful of excessively contaminated fuel can plug a filter. When clogged to the maximum capacity, filters will have a brown to black color or tar like contaminants may be present - this is normal. An appearance of a multi-colored slime (which may have a foul odor) is an indication of microbiological contamination. This condition must be treated immediately.

Severe conditions must be corrected by a repair facility.

Note - Never operate Racor unit without the filter in place - the 'filter safety valve' will not expose outlet hole on fuel return tube if filter is removed and fuel will not flow to engine. Instead, punch emergency tab on the top of filter and leave in place. Puncturing **emergency** tab will bypass all filtration and send unfiltered fuel to your engine. Service filter as soon as possible to avoid harmful contaminants flowing downstream to the final filter or engine.

Water Sensors - This feature alerts operator of a high-water condition. The bowl is then drained of water at earliest convenience. Note - a Racor water detection module is needed to work with the in-bowl sensor. The unit should activate when water reaches sensor tips (and when they measure between 47,000 and 100,000 ohms of resistance, depending on detection module used.) If not, tips may be fouled with a coating. Remove water sensor and clean tips with a cloth. Run a jumper wire between tips with ignition ON to test system.

Difficulties usually lie in the wire connections, power source, or an independent ground.

Heaters - In-filter heaters are starting aids, but may be left on during cold operations to continue to supply heat. The 325 watt heater is an extremely reliable option, but **MUST** be powered via a relay switch due to initial amperage surge at start-up: 27 amps at 12 vdc and 13 amps at 24 vdc. They do not activate unless the fuel is below 50°F (10°C) and automatically deactivate at 80°F (28°C).

Heater Testing - Heaters can only be tested when the thermostat is closed (fuel temperature is below 50°F or 10°C). With a ampmeter attached to external wiring, and engine off, amperage should increase when heater is switched on.

All Racor FH filter assemblies are 100% tested to ensure a leak-proof, quality product.

Note - Correct external fuel leaks immediately! In the event difficulties are experienced with your filter assembly or a problem appears to prevent the engine from running smoothly, refer to the procedures on the previous page. Note - Apply Parker Super O-lube (part number RK 31605) or equivalent to all seals at major attachment points to maintain integrity, seal elasticity, to fill small voids, and to provide protection from degradation.

Perform all checks with engine OFF (and applicable valves closed). For replacement parts, refer to the Replacement Parts section of this manual.

Limited Warranties Statement

All products manufactured or distributed by Racor are subject to the following, and only the following, LIMITED EXPRESS WARRANTIES, and no others: For a period of one (1) year from and after the date of purchase of a new Racor product, Racor warrants and guarantees only to the original purchaser-user that such a product shall be free from defects of materials and workmanship in the manufacturing process. The warranty period for pumps and motors is specifically limited to ninety (90) days from date of purchase. A product claimed to be defective must be returned to the place of purchase. Racor, at its sole option, shall replace the defective product with a comparable new product or repair the defective product. This express warranty shall be inapplicable to any product not properly installed and properly used by the purchaser-user or to any product damaged or impaired by external forces.

THIS IS THE EXTENT OF WARRANTIES AVAILABLE ON THIS PRODUCT. RACOR SHALL HAVE NO LIABILITY WHATSOEVER FOR CONSEQUENTIAL DAMAGES

FLOWING FROM THE USE OF ANY DEFECTIVE PRODUCT OR BY REASON OF THE FAILURE OF ANY PRODUCT. RACOR SPECIFICALLY DISAVOWS ALL OTHER WARRANTIES, EXPRESS OR IMPLIED INCLUDING, WITHOUT LIMITATION, ALL WARRANTIES OF FITNESS FOR A PARTICULAR PURPOSE (EXCEPT FOR THOSE WHICH APPLY TO PRODUCT OR PART THEREOF THAT IS USED OR BOUGHT FOR USE PRIMARILY FOR PERSONAL, FAMILY, OR HOUSEHOLD PURPOSES), WARRANTIES OF DESCRIPTION, WARRANTIES OF MERCHANTABILITY, TRADE USAGE OR WARRANTIES OR TRADE USAGE.

Warning

Failure or improper selection or improper use of the products and/or systems described herein or related items can cause death, personal injury and property damage. This document and other information from Parker Hannifin Corporation, its subsidiaries and authorized distributors provide product

and/or system options for further investigation by users having technical expertise. It is important that you analyze all aspects of your application and review the information concerning the product or system in the current product catalog. Due to the variety of operating conditions and applications for these products or systems, the user, through its own analysis and testing, is solely responsible for making the final selection of the products and systems and assuring that all performance, safety and warning requirements of the applications are met. The products described herein, including with limitation, product features, specifications, designs, availability and pricing, are subject to change by Parker Hannifin Corporation and its subsidiaries at any time without notice.

The following statement is required pursuant to proposition 65, applicable in the State of California: 'This product may contain a chemical known to the State of California to cause cancer or reproductive toxicity'.