

Turbine Series - 900FV/1000FV

FUEL

Specifications: Diesel Applications

Height: 900FV: 17.12" (43.47 cm)
1000FV: 22.23" (56.47 cm)

Width: 8.68" (22.00 cm)

Depth: 7.96" (20.23 cm)

Weight: 900FV: 10.0 lbs (4.5 kg)
1000FV: 10.8 lbs (4.9 kg)

Ports: 1 5/16"-12 UN-2B (SAE 1926-1)
2X 3/4" NPTF Adapters Supplied
2X Port Plugs Supplied

Service Clearance (Top): 900FV: 5.0" (12.7 cm)
1000FV: 10.0" (25.4 cm)

Vacuum Installation Recommended
Maximum Head Pressure: 15 psi (1.03 bar)

Max Flow Rate: 900FV: 90 gph (340 lph)
1000FV: 180 gph (681 lph)

Create a Part Number

Housing Type		Accessory Options		Filteration Rating
Turbine Model 90 GPH Flow Rate	Turbine Model 180 GPH Flow Rate	12 VDC Heater (32.5 watt)	24 VDC Heater (32.5 watt)	10 micron
900FV	1000FV	12	24	10

Dimensions:

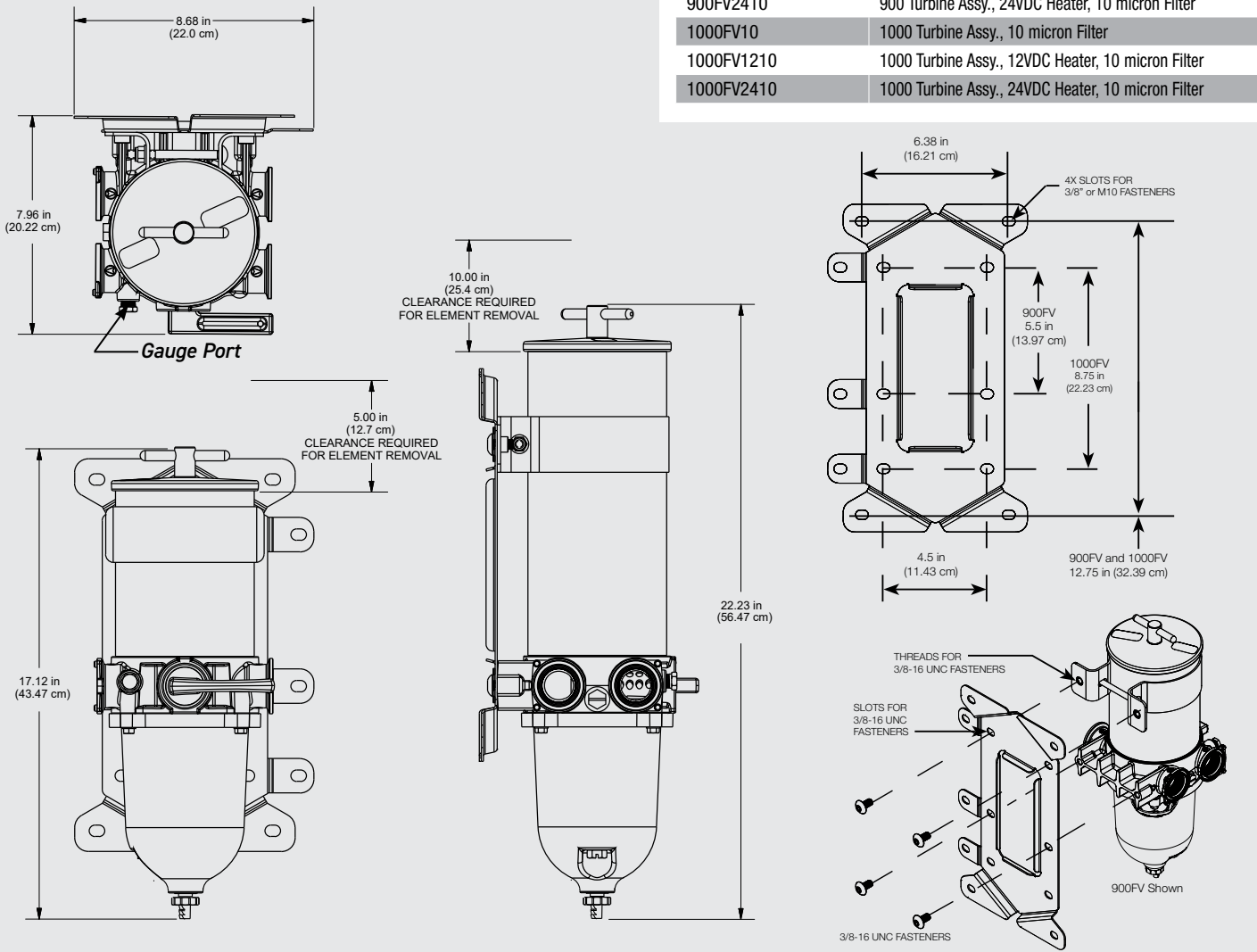

ASSEMBLY	DESCRIPTION
900FV10	900 Turbine Assy., 10 micron Filter
900FV1210	900 Turbine Assy., 12VDC Heater, 10 micron Filter
900FV2410	900 Turbine Assy., 24VDC Heater, 10 micron Filter
1000FV10	1000 Turbine Assy., 10 micron Filter
1000FV1210	1000 Turbine Assy., 12VDC Heater, 10 micron Filter
1000FV2410	1000 Turbine Assy., 24VDC Heater, 10 micron Filter



PARTS

Turbine - 900FV/1000FV Series

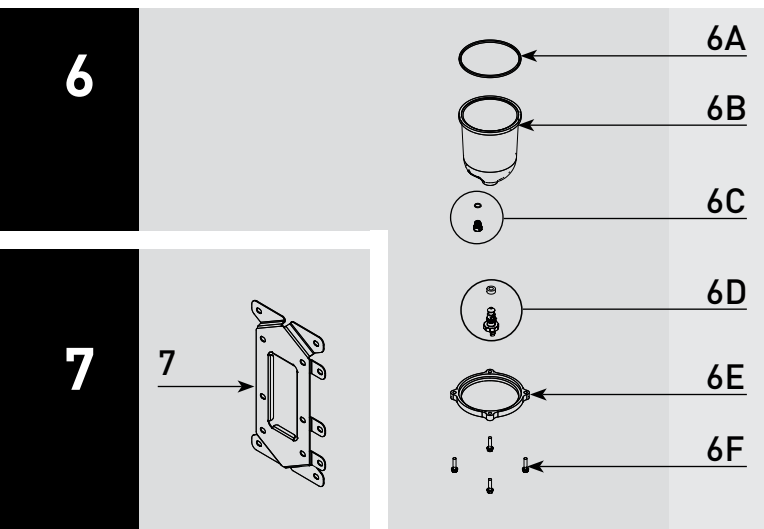
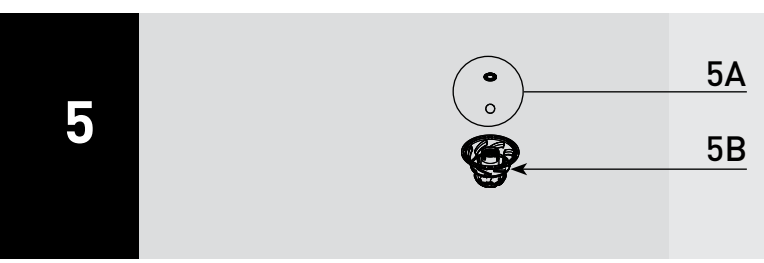
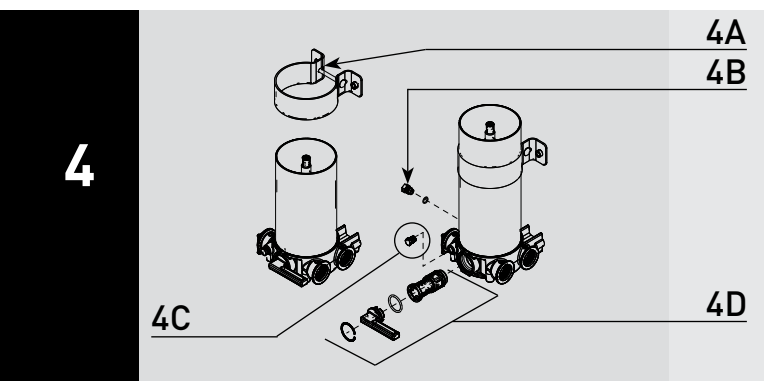
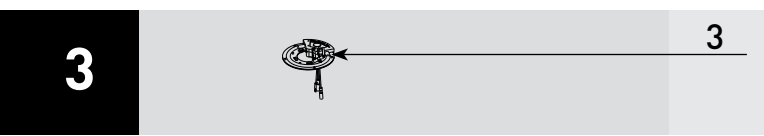
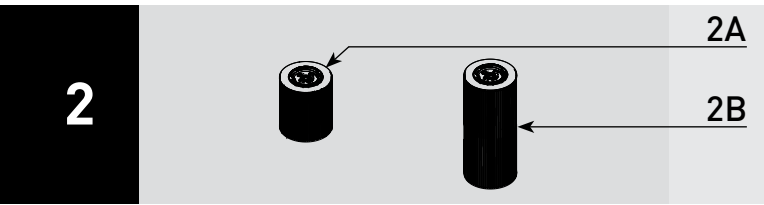
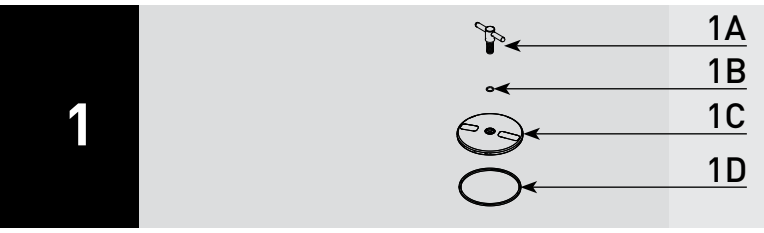

Part #	Description
1A	RK11-2076 T-handle/Lid Kit - Includes 1B, 1C & 1D
1B	T-handle O-ring - Included in 8A
1C	900FV/1000FV Lid
1D	Lid Gasket - Included in 8A

2A	2040V2	900FV Service Filter 2 micron - Includes 1B & 1D
	2040V2LL	900FV Service Filter 2 micron (Long Life) - Includes 1B & 1D
	2040V10	900FV Service Filter 10 micron - Includes 1B & 1D
	2040V30	900FV Service Filter 30 micron - Includes 1B & 1D
2B	2020V2	1000FV Service Filter 2 micron - Includes 1B & 1D
	2020V2LL	1000FV Service Filter 2 micron (Long Life) - Includes 1B & 1D
	2020V10	1000FV Service Filter 10 micron - Includes 1B & 1D
	2020V30	1000FV Service Filter 30 micron - Includes 1B & 1D

3	RK11-2016	Heater Kit - 12 vdc, 325 watt - Includes 1B & 1D <i>Recommended RK 11861 Heater Relay Kit</i>
	RK11-2015	Heater Kit - 24 vdc, 325 watt - Includes 1B & 1D <i>Recommended RK 11862 Heater Relay Kit</i>

4A	RK11-2077	Bracket Kit - Includes Bracket, Bolt, Washer, and Nut
4B	RK 11-1679	Feed-thru Plug - O-ring Included in 8A
4C	RK11-2078	Vacuum Gauge Port Plug
4D	RK11-2079	Valve Rebuild Kit

5A		Checkball and Gasket - Included in 5B and 8A
5B	RK11-2080	Centrifuge/Baffle/Checkball/Gasket Kit - Includes 6A Checkball and Gasket - Included in 8A

6A		Bowl Gasket - Included in 8A
6B	RK11-2081	Bowl Kit - Includes 6A, 6C, 6D, 6E & 6F
6C	RK 20126	Bowl Plug (O-ring Included in 8A)
6D		Self-venting Drain (Gasket Included in 8A)
6E		Bowl Ring
6F	RK 11542	Cap Screw Bowl Fasteners (set of 4)

7	RK11-2083	Mounting Bracket Kit - Includes Bracket & 4 bolts
---	-----------	--

Accessories and Parts Available - *Not Shown*

8A	RK 11-1952	Complete Seal Service Kit - 900FV/1000FV Series Filters
8B	RK11-2085	900FV/1000FV Port Plug & Adapter Kit
8C	RK19671	Stainless Steel T-handle with Vacuum Gauge
	RK19668	Vacuum Gauge (30" Hg) - 1/4" NPT back or remote mount
	RK 19667	Compound Gauge - pressure (15 PSI) and vacuum (30" Hg)
8D	RK 14329	Water Detection Module - 12 vdc
	RK 14321	Water Detection Module - 24 vdc
8E	RK30880E	WIF Sensor/Detection Kit - 1/2"-20 UNF
8F	RK11-1978	Checkball Spring Kit - For use with Primer Pump Kit 8G
8G	RKP1912	Primer Pump Kit - 12 vdc - Adds 3.25" (8.26 cm) to Height
	RKP1924	Primer Pump Kit - 24 vdc - Adds 3.25" (8.26 cm) to Height